

The State of Product Development & Hardware Design 2023-2024

Engineering and manufacturing leaders reveal their top challenges, strategies for success, and experiences adopting newer technologies.

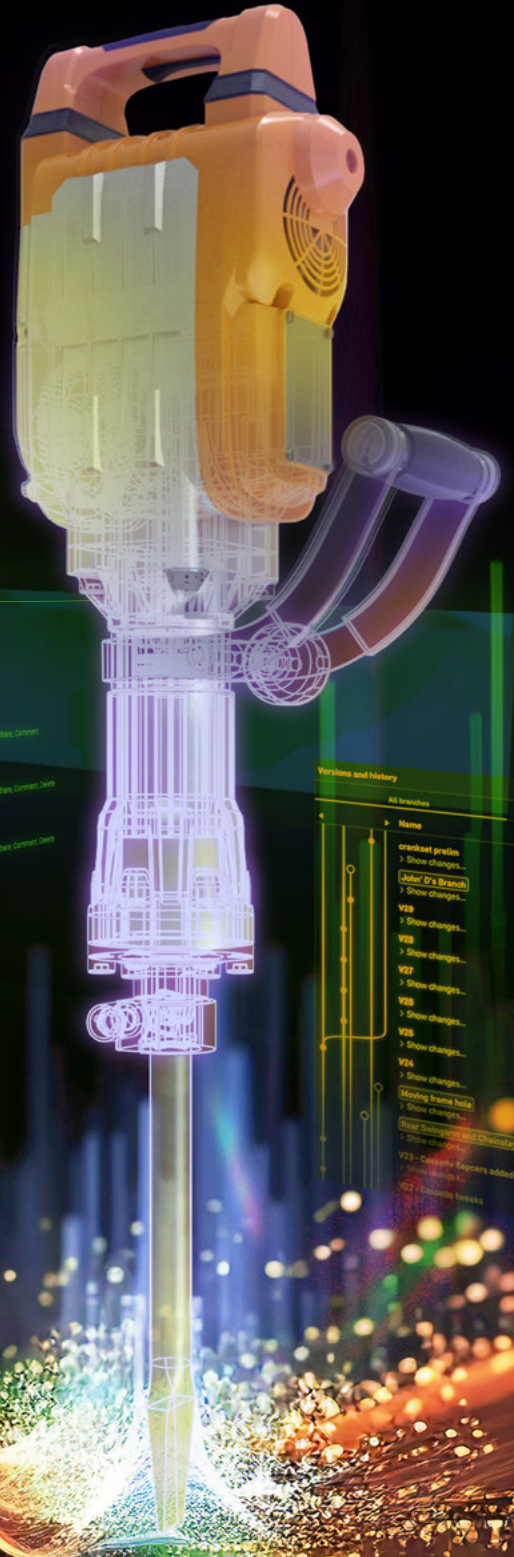

Share settings for
E-Jackhammer

- Manufacturer Can edit
Copy Link Document Export Share Comment
- Mike Manager Can edit
Copy Link Document Export Share Comment Delete
- Me Can edit
Copy Link Document Export Share Comment Delete

Versions and History

All branches		Act
Name	Modified	
crankset prelim		
> Show changes...	David Nguyen	
	11:01 Feb 17	
John's D's Branch	Nacho Martin	
> Show changes...	9:49 Feb 17	
V28	Nacho Martin	
> Show changes...	8:52 Feb 17	
V27	Jake Delano	
> Show changes...	8:12 Feb 17	
V26	Jake Delano	
> Show changes...	18:23 Feb 16	
V25	Jake Delano	
> Show changes...	18:01 Feb 16	
V24	Jake Delano	
> Show changes...	17:28 Feb 16	
Missing frame hole	Jose Lemus	
> Show changes...	10:51 Feb 16	
Final design (not checked)	Mehul Gala	
> Show changes...	9:56 Feb 16	
V23 - Complete Bracers added	Mehul Gala	
> Show changes...	8:28 Feb 16	
V22 - Main body breaks	Michael	
> Show changes...	7:11 Feb 16	

Introduction	page 03
Executive Summary	page 04
Glossary: What are cloud-native, hybrid-cloud and traditional desktop tools?	page 04
Survey Demographics: The mainstream CAD market.	page 05
Insight #1: The 3 biggest challenges facing product development teams today are time waste, communication, and flexible work environments.	page 08
Insight #2: Design professionals are accelerating their transition to newer cloud products.	page 11
Insight #3: Users of cloud-native CAD products are, by far, more satisfied than those using hybrid-cloud or older desktop products.	page 20
Insight #4: Users of cloud-native PDM are much more satisfied than those using separate file-based CAD and PDM solutions.	page 33
Conclusion: Why wait another day to get the benefits of cloud-native CAD & PDM?	page 42
Case Study: How Onshape helped a leading hydrogen energy company speed up product development by 10X.	page 44
Appendix: Additional survey demographics.	page 46

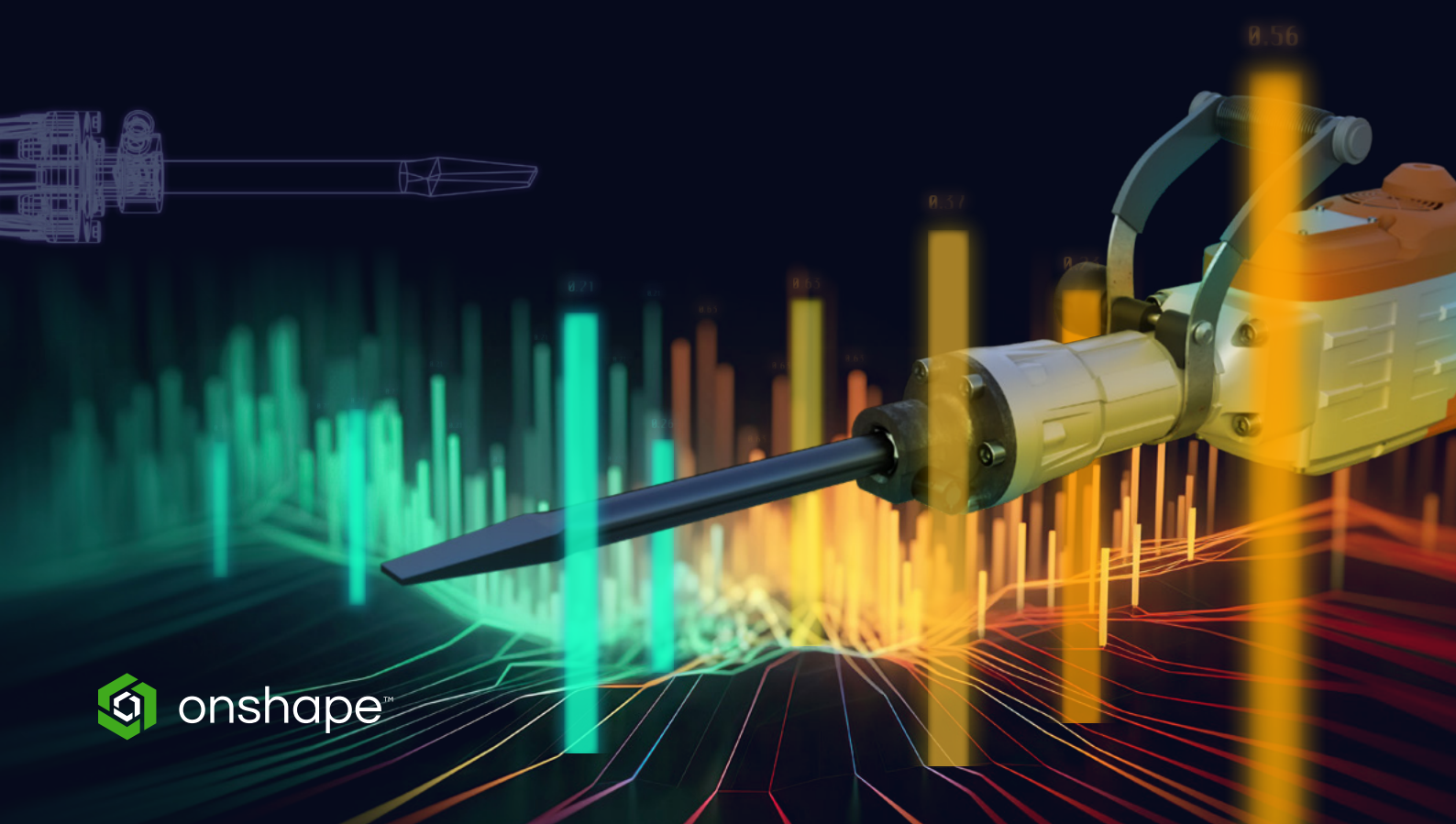

INTRODUCTION

What is the State of Product Development and Hardware Design in 2023?

Since the global COVID pandemic, there has been a climate of uncertainty in the product design industry. Evolving changes include major disruptions to supply chains, inflationary pressures, more flexible work expectations, and more frequent job hopping by top talent. Nevertheless, some companies have proven remarkably resilient.

To explore how engineering and manufacturing teams are preparing for tomorrow's challenges, Onshape commissioned the independent third-party research firm Isurus to conduct a broad-based product development survey.

In this industry report, which took the pulse of **more than 1400 engineering and manufacturing professionals worldwide**, you'll gain insights on the following questions:

- What are the biggest challenges facing product development companies today?
- What changes have product development teams made in the past few years to address these challenges and improve productivity?
- What new tools and technologies are product development teams adopting right now – and how satisfied are they with their choices?



Over the past several years, the annual State of Product Development and Hardware Design report has focused on overall challenges facing product design professionals and their companies. **This year, the report was expanded to address the following topics:**

- How product design professionals are adopting new technologies – especially cloud technologies – to improve their workflows and processes.
- How cloud adoption is affecting the users of 3D mechanical CAD and Product Data Management (PDM) systems.
- The satisfaction level of users of cloud-native CAD and PDM tools versus users of hybrid-cloud tools.

Executive Summary

The 2023-2024 State of Product Development survey results led to four major insights:

- 1** The top three challenges facing product development companies are: reducing time waste, improving extended design team communication, and adapting to more flexible work expectations.
- 2** To accelerate product development, more companies are now transitioning to cloud-native and hybrid-cloud CAD and data management platforms.
- 3** Product design professionals using cloud-native CAD products are dramatically more satisfied than those using hybrid-cloud or desktop products.
- 4** Product design professionals using a combined CAD and PDM solution – one that uses a single interface, a single cloud database, and a cloud-native architecture – are much more satisfied than those using separate CAD and PDM solutions.

In short, companies transitioning their product design workflows to the cloud are reporting immediate and significant benefits.

■ GLOSSARY

Throughout this report, we compare three categories of CAD and PDM software. Here's a brief overview of the differences between them.

Cloud-Native: A product with a software architecture that runs online and stores data securely in a distributed cloud database. Cloud-native software has high availability and scalability, allowing multiple users to simultaneously or asynchronously access the same design data from any device at any time. Cloud-native architectures are optimized for reliability, and eliminate crashes, data corruption, and data loss. They also allow users to roll back to any state of the design that ever existed. Only Onshape has a cloud-native architecture.

Hybrid-Cloud: Hybrid-cloud products may run online and be accessed through a browser, but they create and store data in files. They manage files by uploading and downloading them to the cloud. Only one user at a time can access the evolving CAD data. An example of a CAD product with a hybrid-cloud architecture is Fusion 360 from Autodesk.

Traditional Desktop: Software installed and operated directly on a user's desktop computer, rather than accessed via a web browser. Data is stored and managed in files and often "shared" by making copies and emailing them as attachments or uploading and downloading them.

Survey Demographics: The Mainstream CAD Market

To better understand the current
State of Product Development & Hardware Design,
we analyzed the survey responses of

1466 product design and manufacturing professionals, including users
of more than 14 mainstream CAD, PDM and PLM solutions.

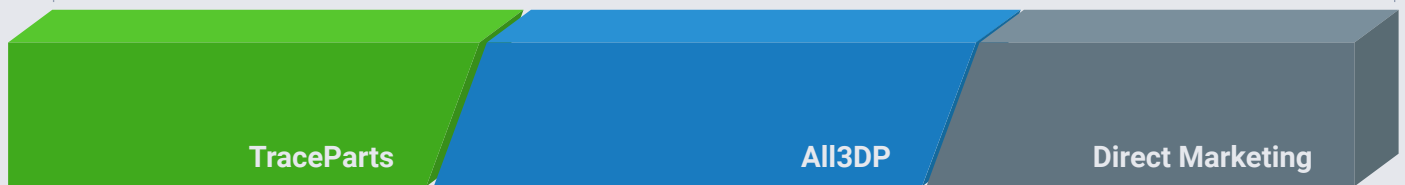

The research firm Isurus reached out to survey respondents anonymously from two independent sources: TraceParts and All3DP, and solicited additional responses through direct marketing. Below is the percentage of respondents from each source.

31.4% **TraceParts** (<https://www.traceparts.com>) is one of the world's largest online sources of product suppliers and standard catalogs with downloadable 3D and 2D product data in all major proprietary and standalone formats. It has over 5,000,000 registered product engineers and designers and provides access to more than 115,000,000 unique part numbers.

36.5% **All3DP** (all3dp.com) is the world's largest digital magazine focused on 3D printing, 3D scanning, CNC, laser cutting and other manufacturing technologies.

32.1% **Direct Marketing** – Additional CAD Professionals were independently sourced through online directories and professional networks.

To qualify as product design professionals, respondents were asked if their company uses a professional 3D mechanical CAD product in their commercial design process. If the answer was "no," they were excluded from the survey.

This survey audience best represents the mainstream CAD market rather than the process-centric CAD market:

- **Mainstream CAD Market** – Characterized by professional design teams most often ranging in size from 1 to 75.
- **Process-centric CAD Market** – Characterized by larger design teams and highly complex manufacturing and supply chains, and usually used in combination with a high-end PLM product.
- **Mainstream CAD Software** – Most commonly SOLIDWORKS® (Dassault Systèmes), Onshape® (PTC), Fusion 360® (Autodesk), Solid Edge® (Siemens), Inventor® (Autodesk).

The trends described in this report were consistent across all three survey audiences.

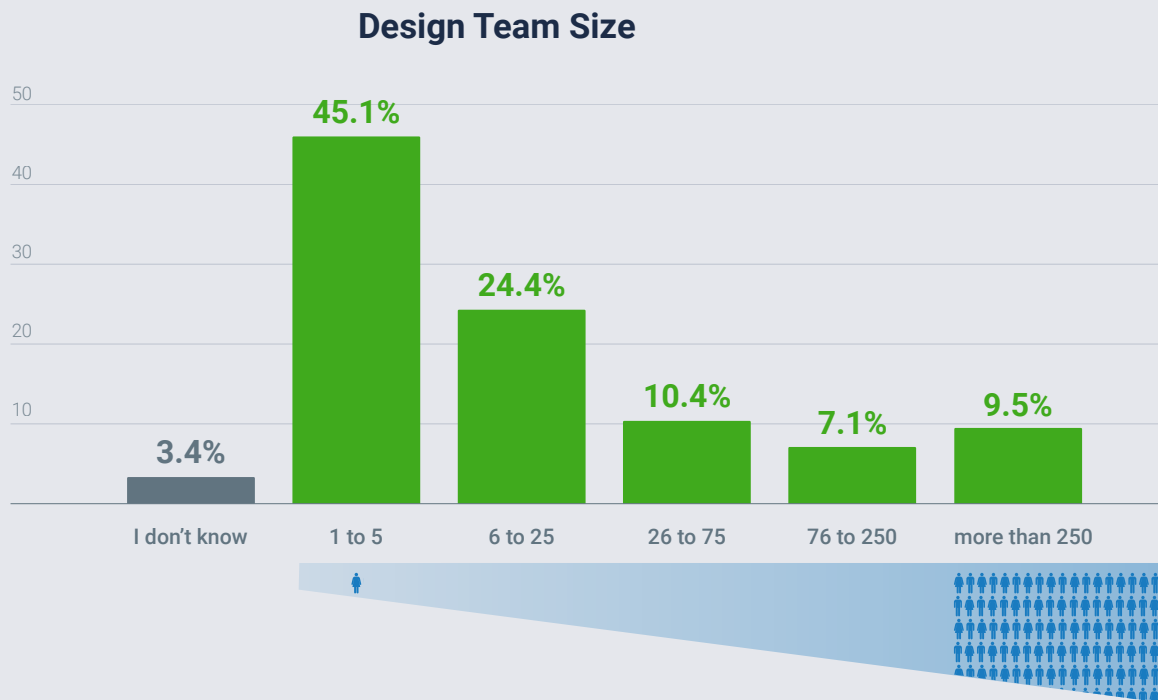

Over 50% of respondents are from design teams of six or more people.

To understand market shifts, respondents were then asked which CAD system and PDM system they used most often for professional work today and which one they used before 2020.

By basing market shift analysis on **actual professional usage**, we avoided inaccuracies often reported by vendors due to bundling newer products with older established products. Primary usage is the best indicator of product adoption.

Note: This independent survey of 1,400+ CAD professionals, while not perfectly representative, provides valuable insights into prevailing trends and viewpoints within the product design industry.



Product Development Survey Insights

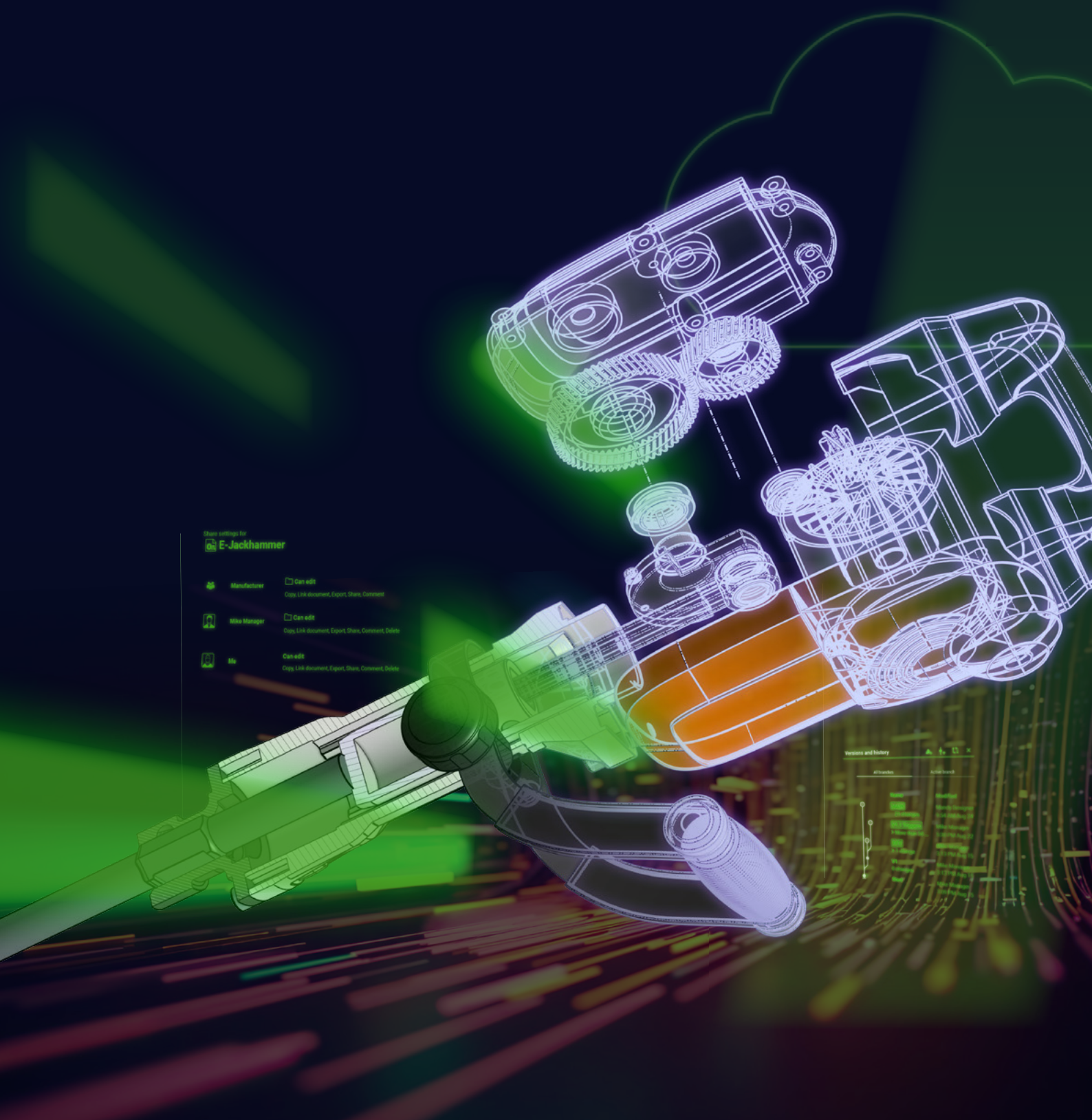

Share settings for
E-Jackhammer

- Manufacturer** Can edit
Copy Link, Download, Export, Share, Comment
- File Manager** Can edit
Copy Link, Download, Export, Share, Comment, Delete
- File** Can edit
Copy Link, Download, Export, Share, Comment, Delete

Versions and History

4/17/2024 10:00 AM





The three biggest challenges facing product design companies are: reducing time waste, improving design team communication, and adapting to more flexible working conditions

Respondents were asked to rate several aspects of their design process, ranging from “Very Poor” to “Excellent.” Below are the two highest and lowest rated aspects.

Respondents that Rated Aspects of Their Design Process as Good or Excellent

Percentage of Respondents



Strong teamwork with poor tools for communication is like the gears of a machine missing lubrication. You have all the right parts, but the machine is sure to grind to a halt.

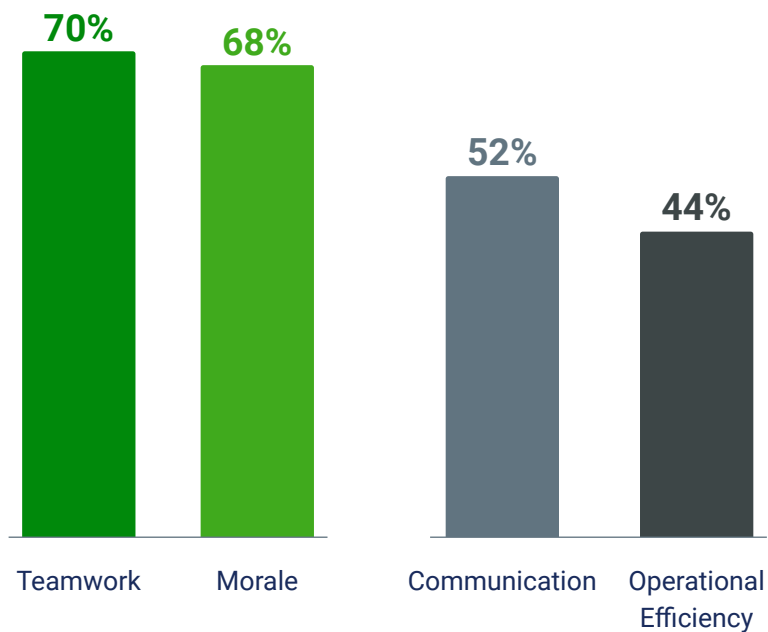

Nearly half or more of all respondents consider their company’s Communication and Operational Efficiency to be “Very Poor” to “Average.” Yet, they rated Teamwork and Morale quite highly. This indicates that while product design professionals often have positive feelings about their teammates and their companies, they still believe their company’s design processes and tools have a lot of room for improvement.

One reason for this might be that strong and talented design teams could be using tools and technologies that impede their productivity. To explore this possibility further, we asked survey respondents to estimate the amount of hours lost per week due to bottlenecks related to their design tools and data.



When collaborating on product designs, how much time do you believe you waste in any of the following areas in an average week?

7.1 hours a week lost to specific CAD and PDM product issues.

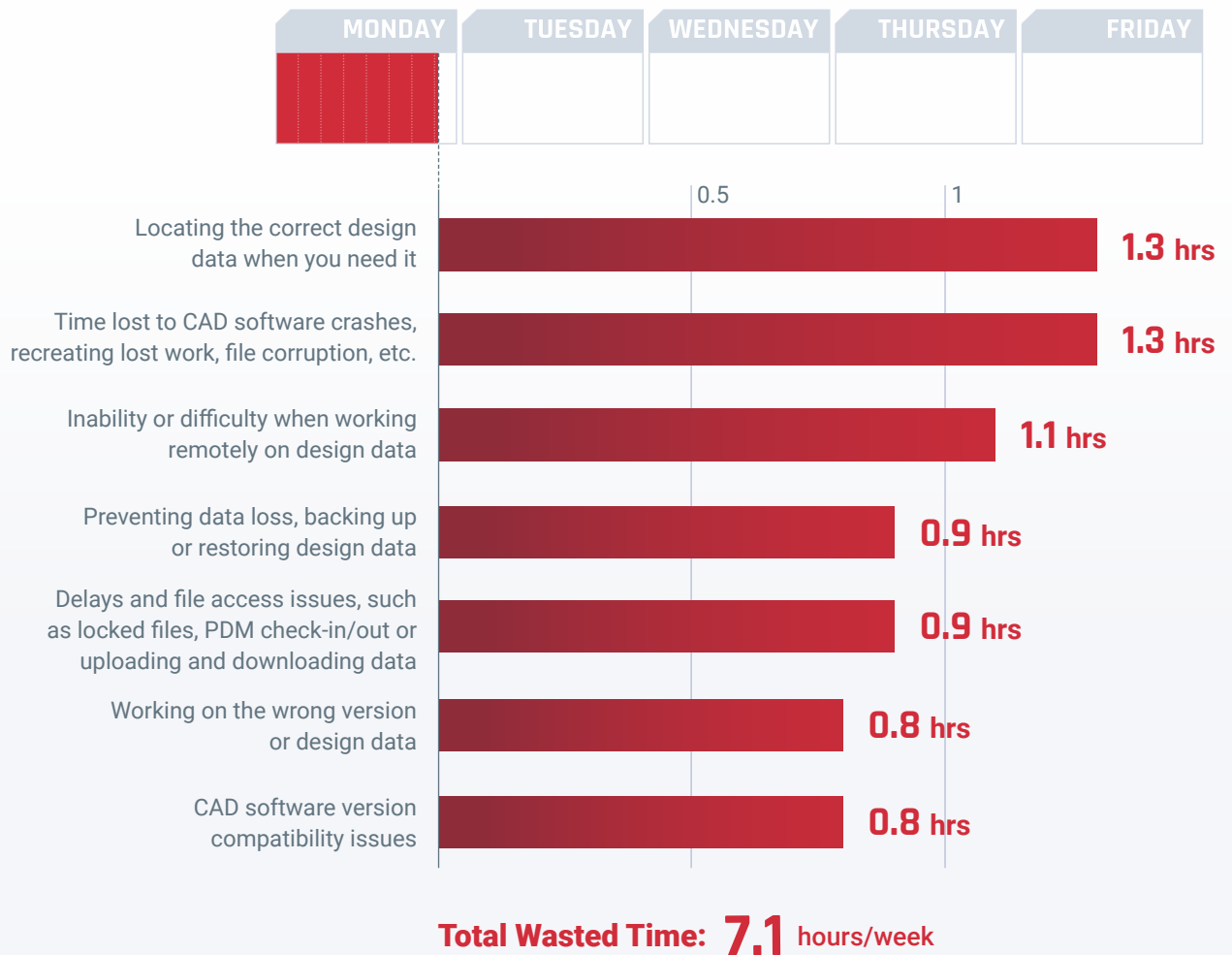

Surprisingly, these specific CAD and PDM product issues alone account for 7.1 wasted hours a week. Note that this doesn't even count the additional time wasted on classic complaints such as too many meetings, inefficient meetings, and waiting for colleagues to respond to emails and messages.

Time lost due to CAD and PDM product issues increases for product design professionals on larger teams, but even for the smallest teams, time waste is still a major issue.

Total Time Wasted Per Week due to CAD/PDM Issues

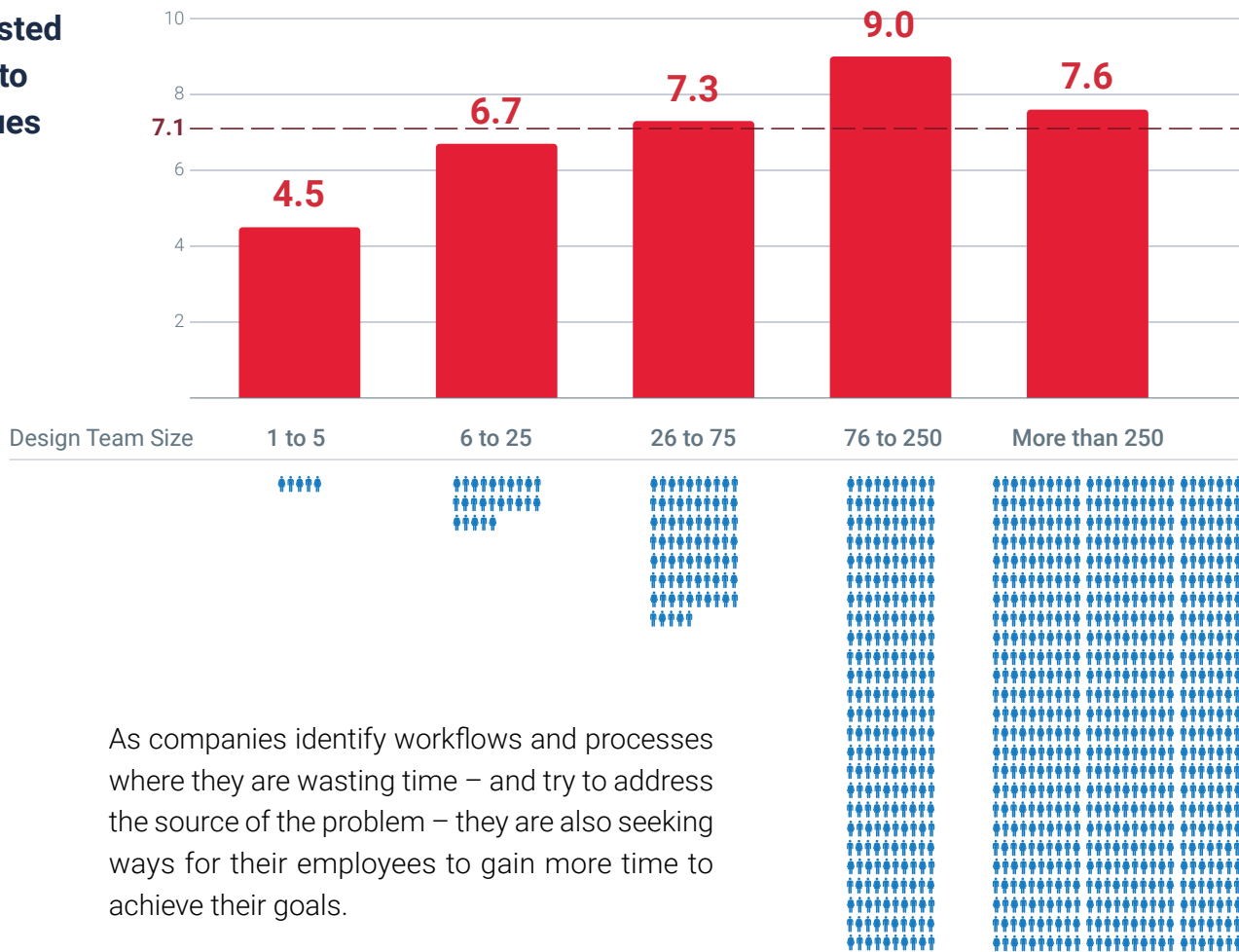

As companies identify workflows and processes where they are wasting time – and try to address the source of the problem – they are also seeking ways for their employees to gain more time to achieve their goals.

Offering a flexible work environment – in both the hours and locations where employees work – is an approach that often results in better productivity and boosted worker morale.

According to [Engineering.com](https://www.engineering.com) and the US Bureau of Labor Statistics, the median age of engineers in the workforce is getting younger. In 2011, the most populous age bracket for engineers was 45 to 54 years old. In 2021, 25-to-34-year-old engineers outnumbered that group by over a quarter million. The latest generation of engineers have never known a world without the internet, cell phones or GPS. They naturally have different expectations of technology and how they are used in the workplace.

Using chat and video collaboration tools like Zoom, Slack, and Microsoft Teams have made flexible work scenarios possible and streamline communication across organizations. Why wouldn't engineers expect these same kinds of real-time chats in their CAD software?

Architectural limitations in desktop CAD and PDM systems hinder work flexibility and data access. As the engineering workforce evolves, patience with outdated design tools will wane, driving an increased demand for modern and intuitive solutions.



Product design companies have accelerated their transition to newer cloud products

Many companies are currently accelerating their transition to newer cloud products. This migration is not just motivated by the promised business benefits, but also because this is the direction all CAD vendors say they are going. All major CAD vendors are now making the cloud central to their marketing campaigns.

Here are just a few examples of cloud positioning from some of the largest CAD vendors:

Cloud CAD is here

- [3DEXPERIENCE SOLIDWORKS Offers](#) by Dassault Systèmes
"Connecting the industry-leading SOLIDWORKS® 3D CAD solution to the 3DEXPERIENCE platform, a single cloud-based product development environment."
- [3D Creator](#) by Dassault Systèmes
"Create 3D Designs with a powerful, intuitive, browser-based solution."
- [Fusion 360](#) by AUTODESK
"Fusion 360 is the first and only integrated cloud CAD, CAM, CAE, and PCB software platform of its kind."
- [ONSHAPE](#) by PTC
"Agile Product Design with cloud-native CAD and PDM. Onshape is helping the world's most innovative companies design better products, faster."
- [Creo+](#) by PTC
"Creo+ combines the power and proven functionality of Creo delivered via SaaS, with new cloud-based tools to enhance collaboration and simplify CAD administration."
- [NX](#) by Siemens
"A fully managed SaaS/cloud-based solution that delivers the full power of NX to customers in a secure, flexible, easy-to-use way via a web browser."

So all CAD vendors are declaring that their future is the cloud. However, it is only in the mainstream CAD market that customers have had a choice between older Windows desktop products and newer cloud products for the past five years.

Since this survey’s respondents best represent mainstream CAD customers, we can get a more accurate snapshot of recent movement in the market.

The Five Major Mainstream CAD Products



In this survey, 75% of respondents in the mainstream market (professionals with design teams of 75 or less) use one of these five products:

- SOLIDWORKS
- Onshape
- Fusion 360
- Solid Edge
- Inventor

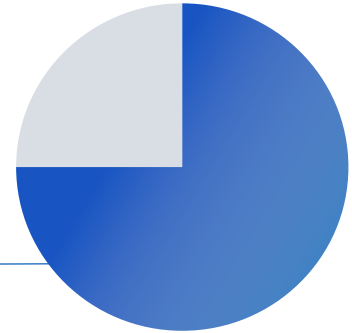
75%



These five CAD products are the only products with a meaningful market share that also derive the majority of their revenue from mainstream users. They can be divided into three groups.

1990s Older Desktop CAD	2010s Newer Cloud CAD	
 <p>Desktop SOLIDWORKS, Inventor, Solid Edge</p>	 <p>Hybrid-Cloud Fusion 360</p>	 <p>Cloud-Native Onshape</p>
<p>These products have file-based architectures. They are installed and run on Windows.</p> <p>While some systems may have added optional cloud storage or “companion” cloud tools, they still operate as an installed desktop product.</p>	<p>Fusion 360 has a hybrid-cloud architecture. It stores data in files locally, but these files are automatically synced to the cloud.</p> <p>The software is installed and runs on a Mac or PC.</p> <p>Only one user can edit a file at a time. Other users will not see changes until the edited file is closed and re-synced to the cloud, and they open it again.</p>	<p>Onshape has a fully cloud-native architecture.</p> <p>Onshape runs in a web browser on any device from PCs, Macs, Linux; and natively on iOS and Android mobile devices.</p> <p>All data is securely stored in cloud databases and computations are done leveraging the cloud.</p> <p>Onshape is multi-user, supporting real-time collaboration on the same data. So unlike Fusion 360, changes that are made on a design are reflected in real time.</p>



If not using one of the five mainstream products, the remaining mainstream respondents were either:

- 10% Using an inexpensive or specialty product (FreeCAD, Rhino, Altium, etc.)
- 8% Using a process-centric solution (Creo, Catia, NX™)
- 7% Using AutoCAD for 3D work

! Note: Dassault's two newest CAD products, 3D Creator and 3D Sculptor, have more cloud-native underpinnings. Only six of the 1466 respondents listed either of these as the product they use most, so the sample size is too small to be statistically meaningful in this analysis.

Momentum

Looking at current users of these five mainstream products and which software they were using three years ago, we can get insights into how the mainstream market is transitioning from older desktop products to newer cloud products.

The following charts compare mainstream CAD users' choice of tools today versus before 2020.

What CAD tool do you use most for professional work today and prior to 2020?

■ Newer Cloud Products (Onshape, Fusion 360)
 ■ Older Desktop Products (SOLIDWORKS, Inventor, Solid Edge)



In just the last three years, the number of mainstream users using newer cloud products almost doubled from 15.9% to 28.3%

To be clear, SOLIDWORKS is still the 800-pound gorilla in the mainstream market, representing 56% of survey respondents in 2023. But before 2020, SOLIDWORKS represented an even higher 64% of respondents. The gorilla is losing some weight.

In the past 3 years, 1 in 8 SOLIDWORKS respondents in the mainstream market switched CAD software.

Percentage of Survey Respondents Using SOLIDWORKS

■ SOLIDWORKS ■ Other Mainstream CAD Softwares (Onshape, Fusion 360, Solid Edge, Inventor)



SOLIDWORKS Attrition by 2023 **8.2%**

So where are the SOLIDWORKS users going? In the survey, SOLIDWORKS users were primarily switching to Onshape. A smaller but still meaningful percentage were switching to Fusion 360.

60% Switching to Onshape **36.2% Switching to Fusion 360**

Where new Onshape Users are coming from

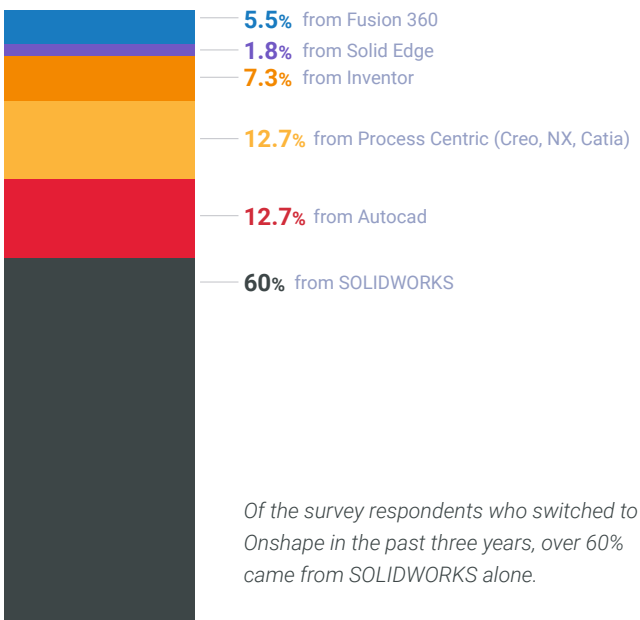

Where new Fusion 360 users are coming from

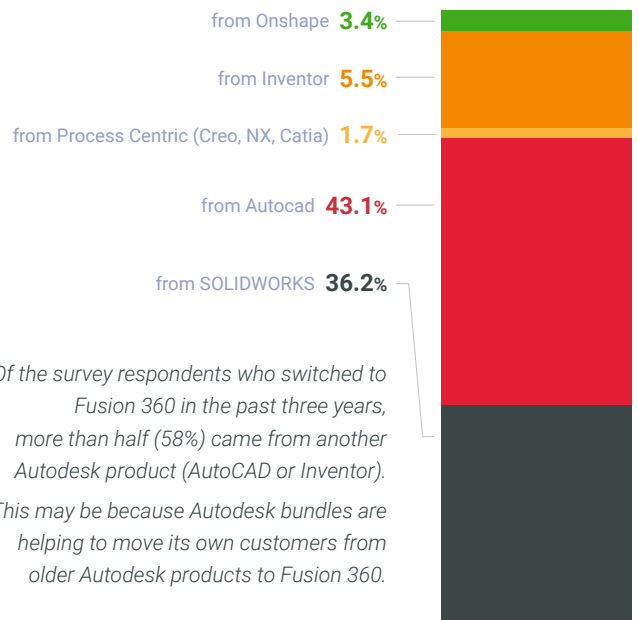

The mainstream CAD market is gradually shifting to newer cloud products. While both Onshape and Fusion 360 are making gains, Onshape is making more headway in capturing users from larger companies and those using process-centric tools.

Onshape is Enterprise Ready Today

12.7% of users who switched to Onshape in the last 3 years came from a process centric CAD tool (Catia, NX, and Creo).

Only 1.7% of users switching to Fusion 360 came from a process centric tool.

ARE COMPANIES OF ALL SIZES MAKING THE TRANSITION?

Yes, they are. One way to assess the size of companies making the transition is to look at the size of the design teams. Major shifts in markets usually start in small to medium-sized businesses first because it is much easier for small teams to transition to new tools than it is for large teams. This is especially true for CAD software due to factors such as employee retraining, proprietary data formats, and integrations with other products.

The survey revealed that users of Fusion 360 tended to be part of smaller design teams (1 to 5 users), whereas Onshape and SOLIDWORKS were more evenly split between small and larger team sizes.

Team Size for Users of SOLIDWORKS, Onshape and Fusion 360 in 2023

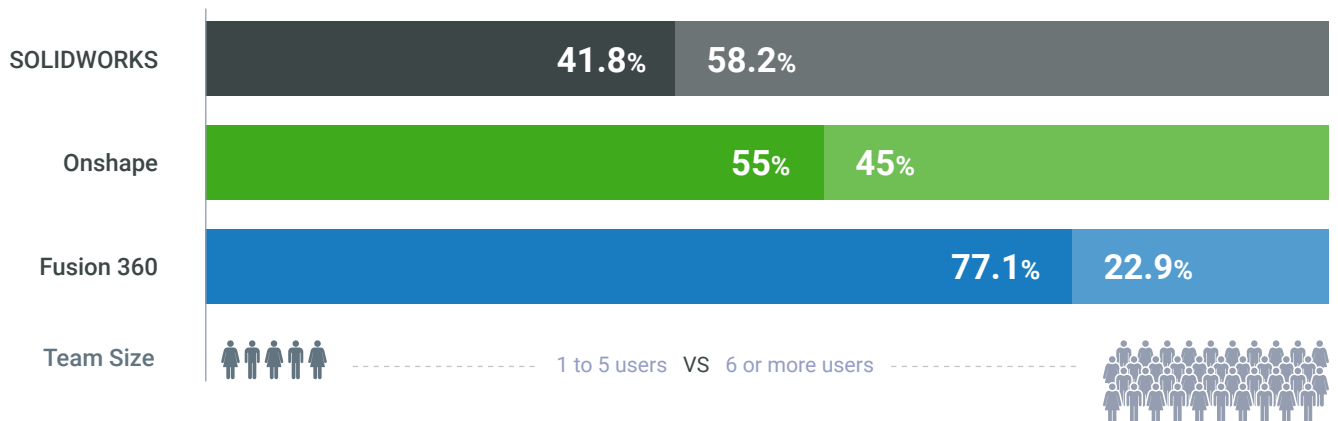

If team size is an indication of manufacturing scale, this data suggests that Onshape is more attractive than Fusion 360 to companies doing more complex work.

It's also clear from the survey that SOLIDWORKS users are migrating to newer products, but why?

WHAT'S HAPPENING WITH SOLIDWORKS?

- 1995** First released in 1995, SOLIDWORKS quickly became dominant in the CAD world by offering the first system to run on personal computers versus mainframes and proprietary terminals (CAD vendors previously made their own hardware).
- 2019** At their SOLIDWORKS World user conference in 2019, Dassault Systemes launched the debut of cloud-based 3DEXPERIENCE Works (3DX) and has been promoting cloud companion products for SOLIDWORKS ever since. This migration to cloud inspired the rebranding of SOLIDWORKS World to 3DEXPERIENCE World.

» [Read the Engineering.com Article](#)
- 2023** However, during the April 2023 Q&A with US investors, COO Pascal Daloz said that “3DEXPERIENCE WORKS has had slow uptake among the SOLIDWORKS base, perhaps only 3% so far,” but noted that “this was to be expected since this offering was launched to attract new logos.”

» [Read the Analyst Blog](#)
- 2023** To encourage adoption at 3DEXPERIENCE World 2023, pricing and licensing changes were announced including:

 - New purchases of SOLIDWORKS Desktop will include 3DEXPERIENCE Cloud services with the subscription.
 - New subscription and term licenses of SOLIDWORKS Desktop products will experience an uplift in price.
 - New SOLIDWORKS Desktop perpetual licenses will require a minimum two-year subscription.

» [Read the SOLIDWORKS Blog](#)

NOTE: Dassault’s two newest CAD products, 3D Creator and 3D Sculptor, have received mixed reviews on user forums. However, the survey response from those users was too small to be statistically meaningful for this report.

Once a company commits to a CAD system, there is a natural period of inertia. Buying a product development platform is a significant investment and engineers become comfortable with the system they are used to – and are likely reluctant to change.

Despite all these factors, many forward-thinking companies are eager to evaluate new technologies. To explore the level of urgency for cloud migration, we asked respondents about their plans for the near future.

Beyond the Chasm: Cloud CAD Goes Mainstream

23% of respondents say they expect to change CAD systems in the next 5 years.

The momentum is building, and it is reasonable to assume that the transition from SOLIDWORKS to newer cloud platforms will accelerate.

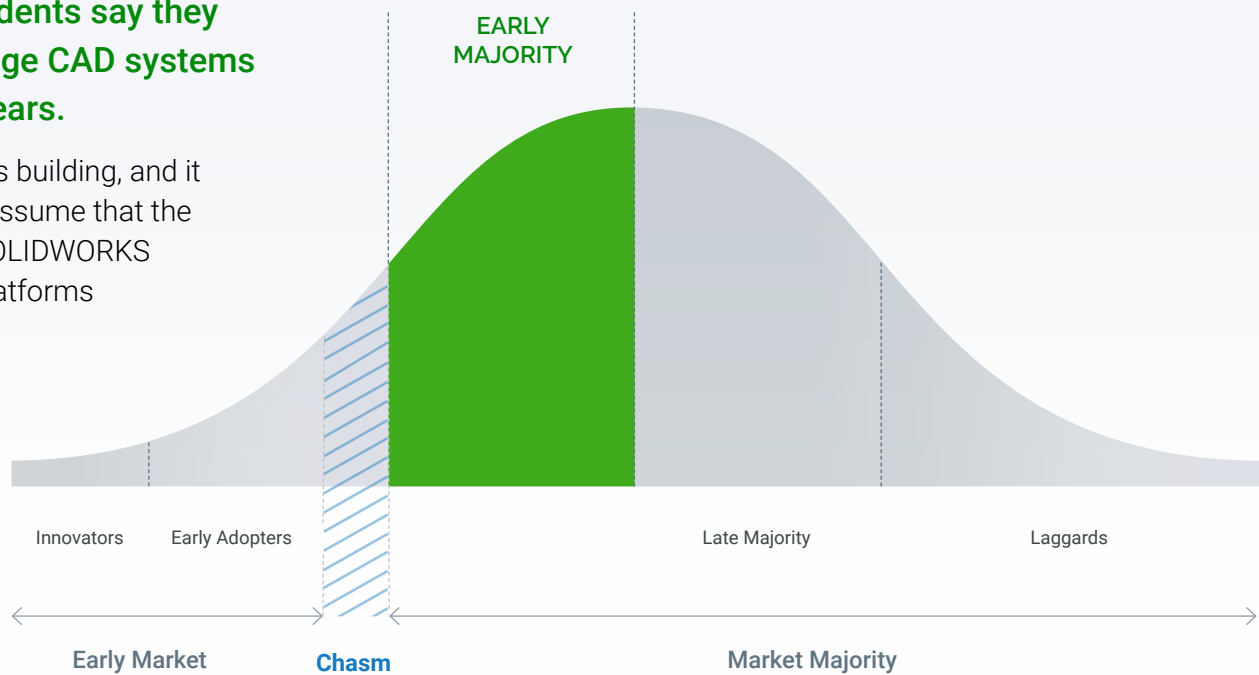

Moore, G. A. (1991). *Crossing the Chasm; Marketing and Selling High-Tech Goods to Mainstream Customers*

One reason many users have transitioned to newer products may be that both Onshape and Fusion 360 have added substantial functionality in the last three years and are now viewed as “caught up” to traditional desktop systems.

To better understand the motivation to change CAD platforms, we asked professionals to share how they feel about their current tools in regards to functionality and the rate of software updates and improvements.



How would you rate your satisfaction with the following aspects of your primary CAD & PDM system?



FUNCTIONALITY

Newer cloud products have caught up to older desktop products when it comes to functionality.

Adopting cloud-based solutions brings its own set of challenges. Newer cloud-based products, once considered inferior in capabilities, have now caught up to, and in some cases surpassed, their older desktop counterparts. This evolution ensures that users benefit from the convenience of cloud platforms without compromising on robust features and capabilities.

Satisfaction with Functionality

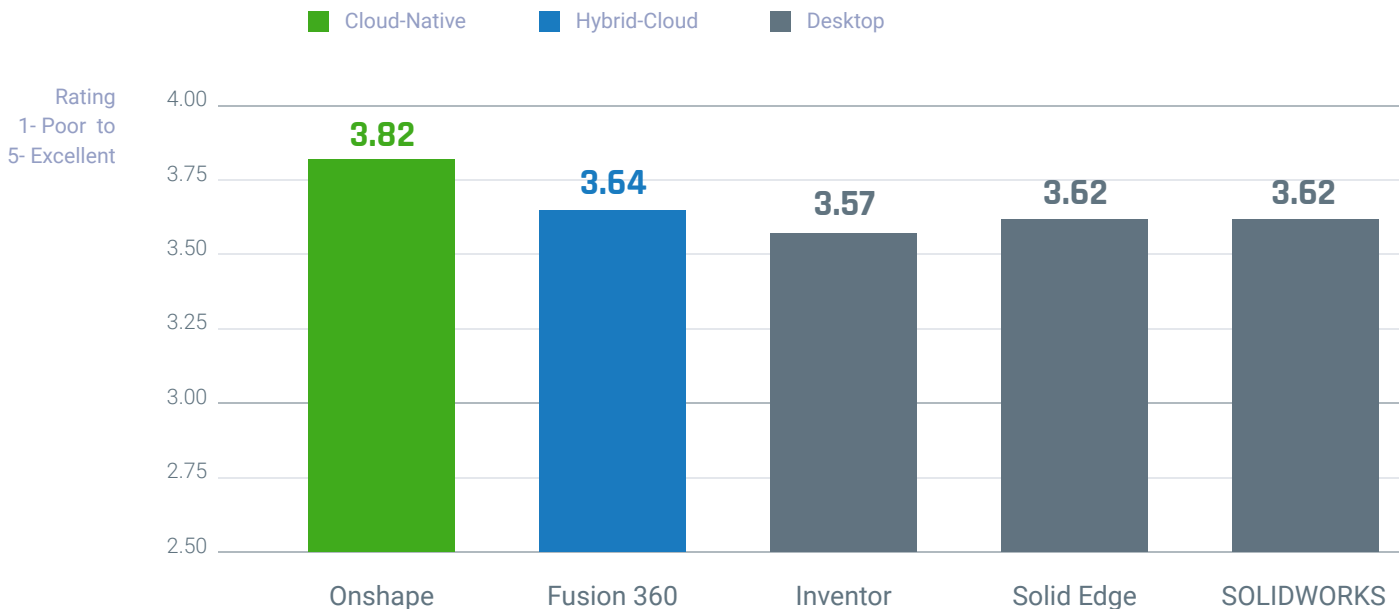

Users of all five mainstream products rated their CAD software’s “functionality” similarly, indicating that users of newer products are just as satisfied as users of desktop products. Given that many of Onshape’s customers are former SOLIDWORKS users, it’s logical to conclude that Onshape now meets the functional requirements of mainstream CAD users.

RATE OF SOFTWARE UPDATES AND IMPROVEMENTS

Cloud-native products deliver software updates and value faster than hybrid-cloud and older desktop products.

Desktop software’s annual update schedule can lead to outdated functionalities and prolonged exposure to security vulnerabilities. Users face a steep learning curve when updates do arrive and there are often upgrade errors, given the bulk of changes introduced at once.

Meanwhile, cloud solutions offer more frequent improvements that do not require installation, ensuring timely access to the latest features and security enhancements with no extra work.

Here’s how the five mainstream CAD platforms stack up:

Satisfaction with Rate of Software Updates and Improvements

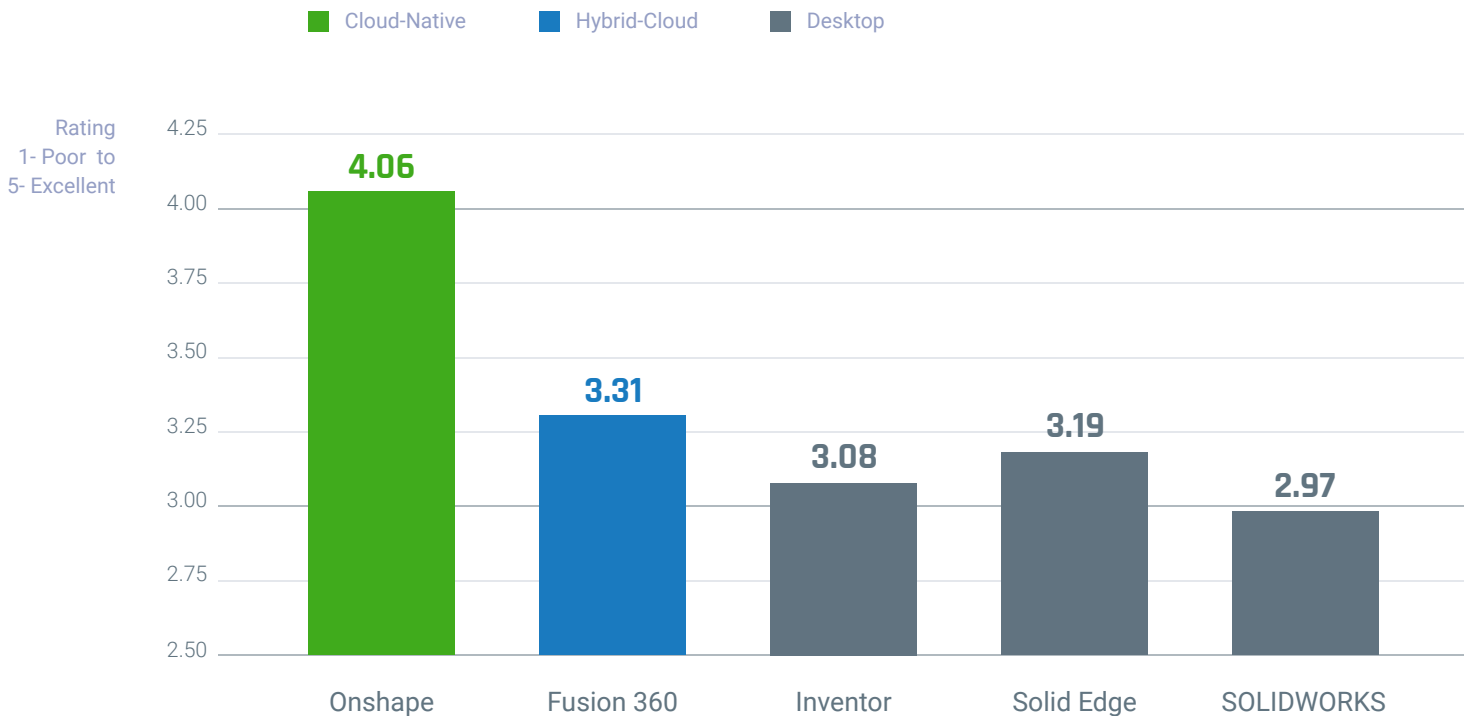

Not surprisingly, cloud-native Onshape scores significantly higher in this category than its desktop competitors, with cloud-hybrid Fusion 360 coming in a distant second - scoring similar to Desktop products. Onshape delivers product updates in the cloud every three weeks versus having to wait a year for new features and improvements.



Product design professionals using cloud-native CAD products are, by far, more satisfied than those using hybrid-cloud or older desktop products

Products succeed in the long run because they solve users' problems better than their competition. The transition to cloud-native and hybrid-cloud products appears to be speeding up, but why? It is because of the concrete benefits that cloud architectures bring to the design process.



We've seen this before in the CAD industry. A good example is the introduction of SOLIDWORKS and Solid Edge in the mid 1990s. Every vendor back then was talking about making their 3D CAD products available on Windows PCs. But most of them were just porting existing UNIX workstation-based solutions rather than rebuilding their software using a true Windows architecture.

In the 1990s, both SOLIDWORKS and Solid Edge gained a huge first-mover advantage by fully committing to the new 32-bit Windows architecture. That architecture gave them major differentiating capabilities – such as ease of use, ease of learning, ease of integration with office productivity tools, and huge hardware cost advantages. Windows computers were far more affordable than the UNIX workstations they needed to run their legacy 3D CAD system.

Eventually, all of the other legacy 3D CAD products were forced to fully commit to a Windows architecture. But many moved slowly, so they either lost ground or even disappeared. It wasn't just running on a Windows machine that made SOLIDWORKS and Solid Edge successful back then – it was fully committing to it architecturally so that users saw the benefits.

It is clear that all CAD vendors are now talking about transitioning to the cloud. And it is clear that the movement from older desktop products to cloud-native and hybrid-cloud products is accelerating. But is every vendor doing "cloud" in a fully committed way? Or are some products doing it in half measures?

To better understand the relationship between software architecture and product development benefits, we looked at users' level of satisfaction and their likelihood to recommend their solution to others.

To do this, survey respondents were asked the same question used to determine the [Net Promoter Score](#) (NPS), the predominant customer satisfaction measure used across many industries.

By comparing NPS scores across the three architectures – cloud-native, hybrid-cloud, and desktop – we can measure each architecture’s influence on customer satisfaction.

Likelihood to Recommend



NPS is computed by asking “How likely is it that you would recommend your primary CAD system to a friend or colleague?”.

[LEARN MORE](#)

Users of cloud-native CAD software are most satisfied, and much more likely to recommend their solution to others than are users of older desktop products.

Note: NPS scores can vary by product and service category. The NPS score can range from -100 (all detractors) to 100 (all promoters) with 0 indicating users are equally likely to be promoters or detractors. For software applications, 30 is considered a typical median score.

NPS Scores by CAD Architecture

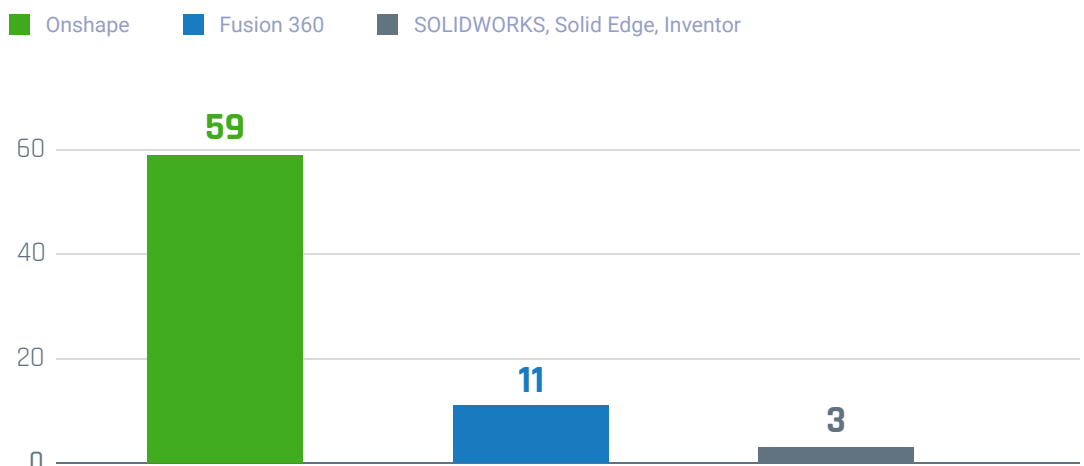

Clearly, cloud-native Onshape users are much more satisfied than users of hybrid-cloud products like Fusion 360 and older desktop products like SOLIDWORKS, Solid Edge, and Inventor.

Insight #2 reviewed user feedback based on functionality and the rate of software improvements. For a deeper understanding of product satisfaction, we asked respondents to rate other critical aspects of their primary CAD software.

AVOIDANCE OF CRASHES AND DATA LOSS

Cloud software virtually eliminates the typical causes of software crashes, leveraging redundant servers and distributed data centers for consistent performance and stability.

CAD crashes are a major time waste, especially when they result in lost work. Accidentally overwriting or deleting a file is also a major problem in file-based desktop CAD products, regardless of whether those files are stored on-premise or in the cloud.

Here’s how the five mainstream CAD platforms compare for stability:

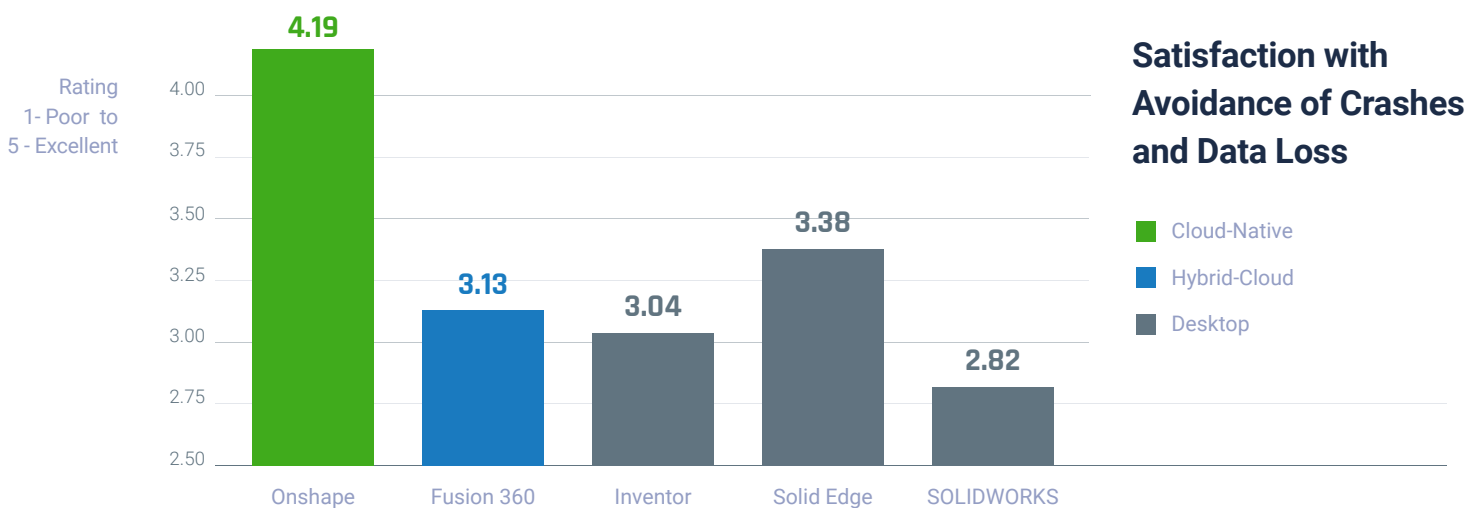

Architecturally, Onshape’s cloud-native CAD and PDM solution cannot “crash” to disk. With Onshape, if you lose your internet connection briefly, your data is not lost because it is stored in a microversion after every operation. You simply refresh the page to get back to the same state. In fact, **Onshape is the only CAD system in the world that also allows users to roll back to any state of the design that ever existed.**

As far as crashes and lost work are concerned, hybrid-cloud solutions such as Fusion 360 are still file-based and have similar crash and data loss issues as desktop products. SOLIDWORKS in particular has the worst crash and data loss score by a substantial amount.

Respondents were also asked to rate a more general quality aspect – “Reliability.” Scores showed the same overall trend again, though the spread between mainstream CAD brands narrowed.

RELIABILITY

Cloud solutions offer customers dependable performance, and are available and operational without disruption and without the need for IT administration.

Minimizing downtime is critically important to design teams because unplanned interruptions can result in missed deadlines, and the potential for missed business opportunities. Cloud technology has raised the bar for users' expectations. Today's users expect 24/7 availability, seamless updates without service interruption, and virtually zero downtime.

Here's how the five mainstream CAD platforms compare for reliability:

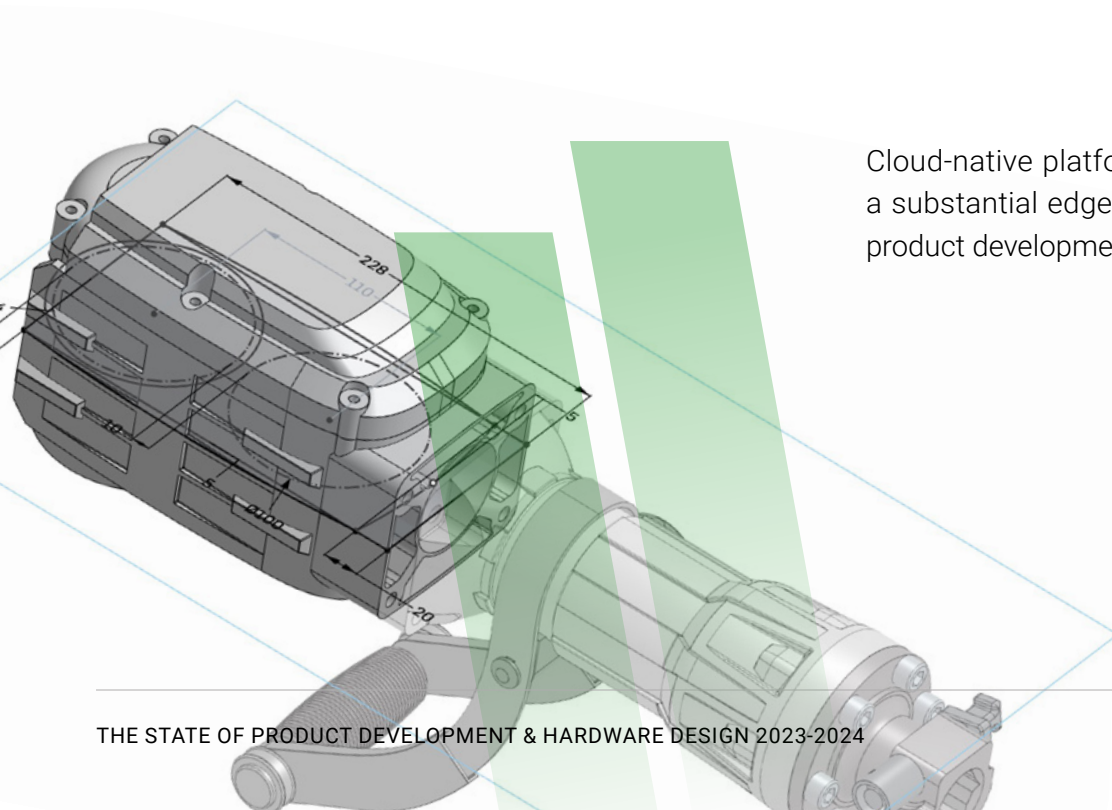
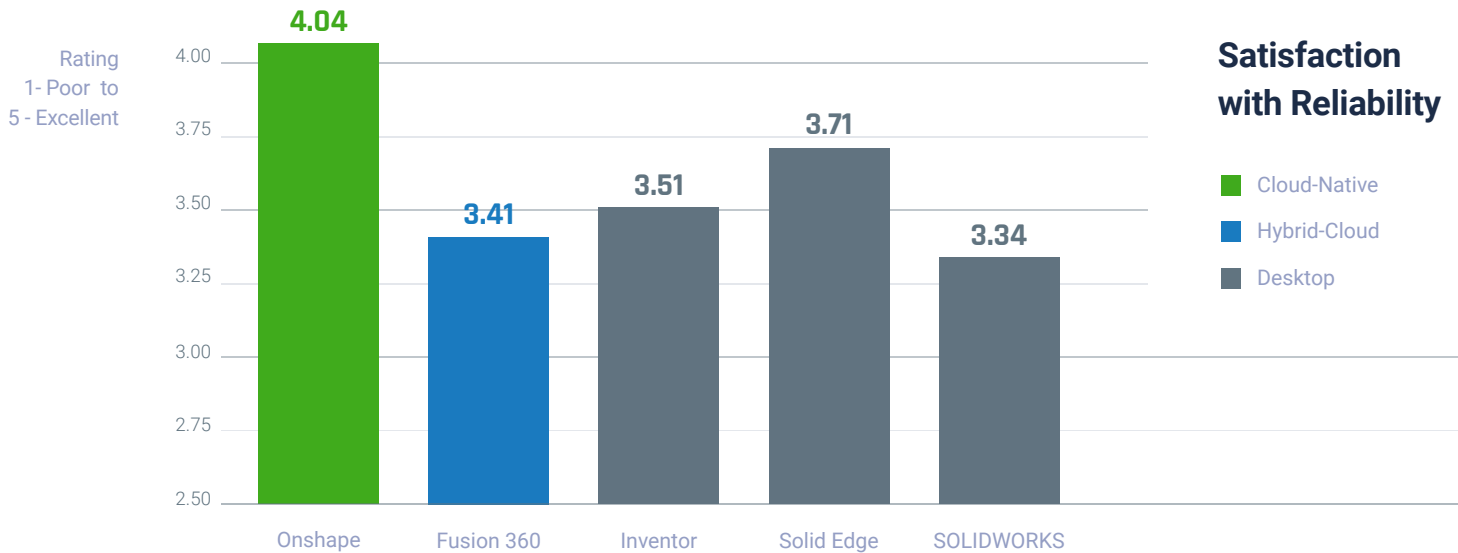

Cloud-native platforms such as Onshape have a substantial edge in minimizing downtime for product development teams.

COLLABORATION

Cloud solutions help teams work together in real time like they are working side by side – even if they are actually miles apart.

Insight #1 made it clear that respondents view design team communication and data access as major areas that need improvement. Collaboration in product development is essential to harnessing diverse expertise and ultimately driving the success of a business. Cloud technologies have reshaped collaboration by promoting transparency through shared access to data – allowing for increased visibility and accountability in work processes.

Here’s how the five mainstream CAD platforms compare for collaboration:

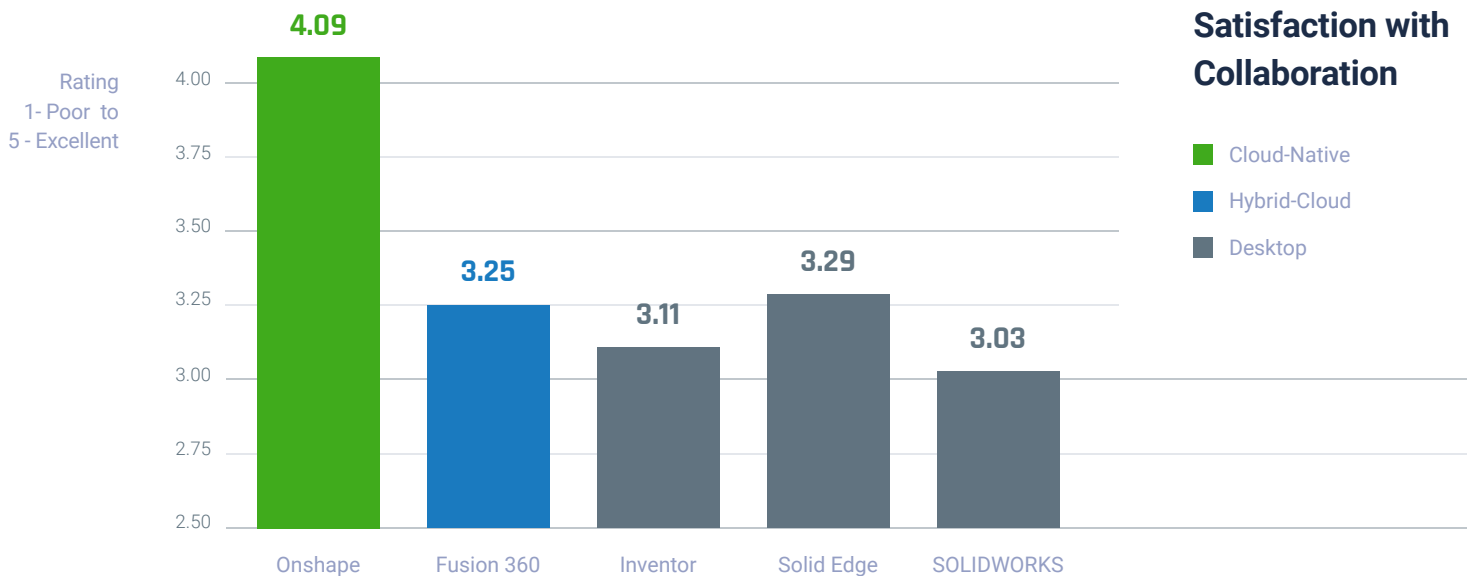

Cloud-native Onshape is a multi-user platform that was built for collaboration, and their users are highly satisfied with this dimension of their experience. It is the only CAD product that allows both full-time CAD users and the extended design team to access the evolving design with an appropriate user experience for their level of CAD expertise and with access rights suitable for their role.

Desktop solutions and hybrid-cloud solutions allow only one user at a time to access the evolving CAD data. In Onshape, access by non-editing users is free. In the other CAD products, a user must often export a snapshot of data to another format (like a markupable viewer, screenshots, or a drawing in .dwg or .pdf formats) that can be viewed in a less expensive way. Those snapshots easily become out of sync with the current evolving design, causing miscommunication, errors, and frustration.

ACCESSIBILITY

Cloud has greatly enhanced accessibility, eliminating geographical and device limitations, thereby making software and data available from anywhere with an internet connection.

Downtime or blocked access to design data and tools can bring manufacturing to a grinding halt. Accessibility has become even more critical in today's flexible work environments.

Imagine an engineer who faces challenges like:

- *Needing to access data remotely.*
- *Being blocked when someone else has the file checked out.*
- *Working off a copy of a file that is out of date.*
- *Not being able to access up-to-date design data from mobile devices.*

Issues such as these all result in a low accessibility rating for desktop solutions and for hybrid-cloud solutions.

Here's how the five mainstream CAD platforms compare for accessibility:

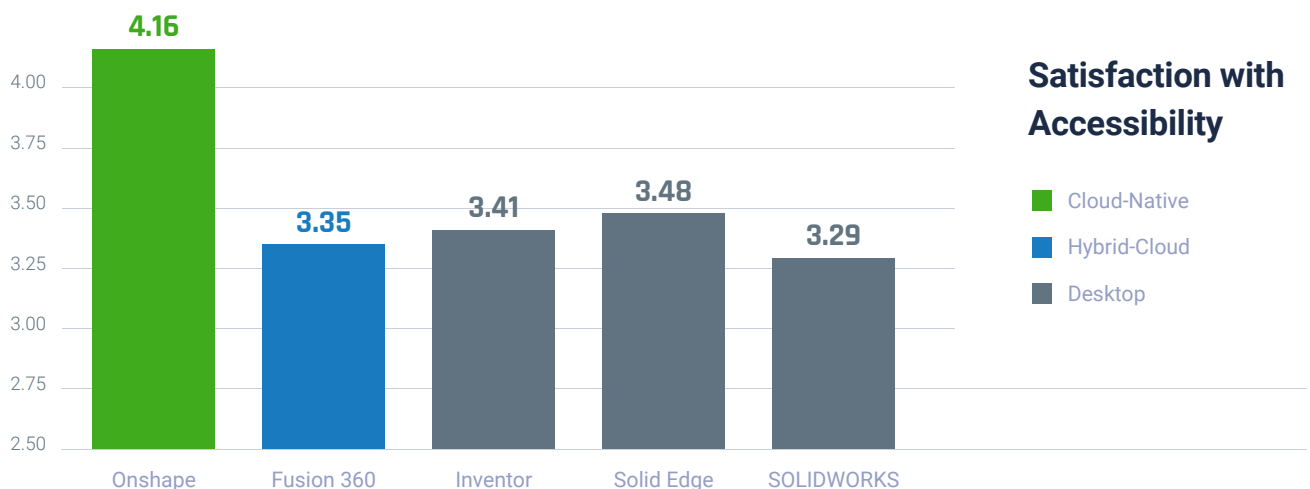

Relying on files instead of the cloud hinders accessibility. Recall that because desktop systems are based on 1990s technology, they run almost exclusively on Windows computers. The implication of this is that only a single user can have write access to a file at a time. Files are “shared” by making copies, which easily become out of sync. Even traditional PDM works by downloading copies of CAD files from a vault – one copy for each user that needs it.

Hybrid-cloud solutions, such as Fusion 360, make this situation somewhat better by updating files to the cloud more frequently. Still, once one person is editing, the evolving design is off limits to everyone else.

IT ADMINISTRATION

Cloud has transformed IT administration budgets by providing more flexibility in scaling up or down as needed, and reducing the burden of maintaining and upgrading hardware and software.

Of course, IT administration is a bigger burden at bigger companies. But it would be a mistake to think that administrative issues are only a problem for large design teams. On smaller design teams, often the best engineer or designer ends up doing most of the administrative and IT tasks.

Wouldn't it be better if the best engineer could spend more of their time solving design problems? With Onshape, they can.

Here's how the five mainstream CAD platforms compare for IT administration:

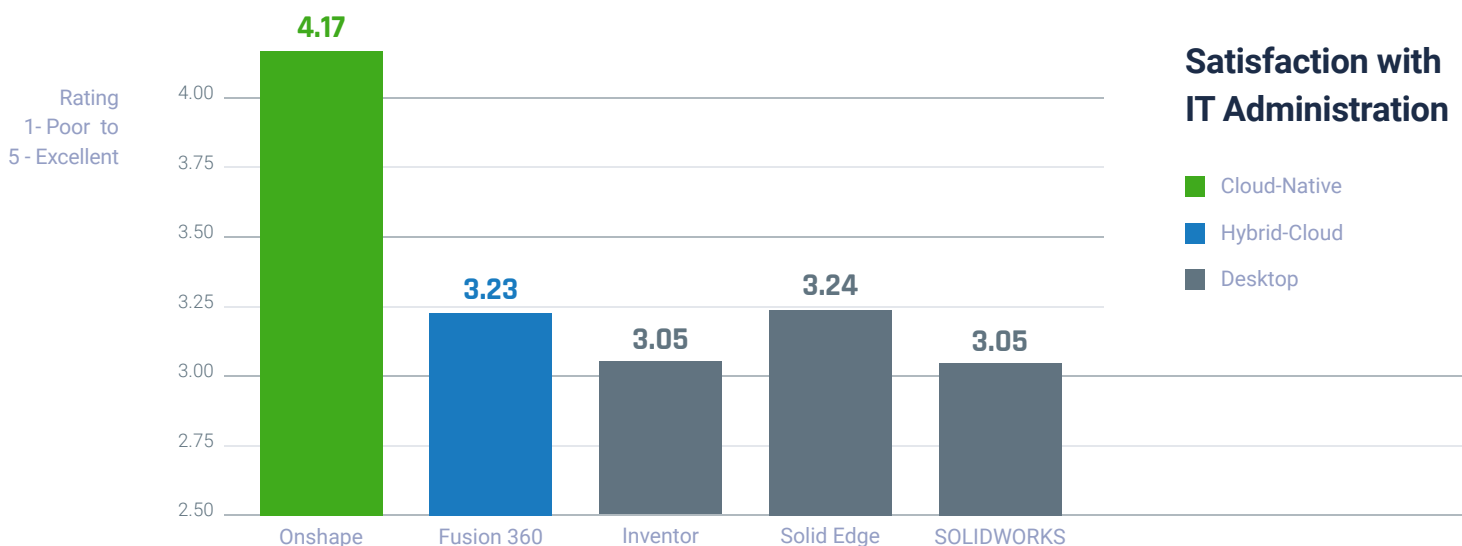

Onshape is by far the easiest to administer according to respondents.

Onshape's CAD and PDM platform is a managed service delivered reliably 24/7 with 99.99% uptime. There are no downloads, installs, and all users are always guaranteed to be on the latest version. Data is saved automatically as you go and is always backed up. This eliminates the bulk of painful administration chores required by other products.

Moreover, Onshape is the only CAD product with built-in user management and team management. Onshape allows administrators to manage users and their access rights directly in Onshape. That means changing a user's access rights to CAD data – such as assigning role-based access controls, projects, and groups – is instantaneous.

SECURITY

Cloud enhances cybersecurity with better data protection, access control, and threat detection.

In an increasingly globalized marketplace, product development companies are acutely aware that security lapses can lead to intellectual property theft, eroding their competitive position. Robust security measures are essential not only to protect sensitive data, but to maintain trust with clients and supply chains.

Here's how the five mainstream CAD platforms compare for security:

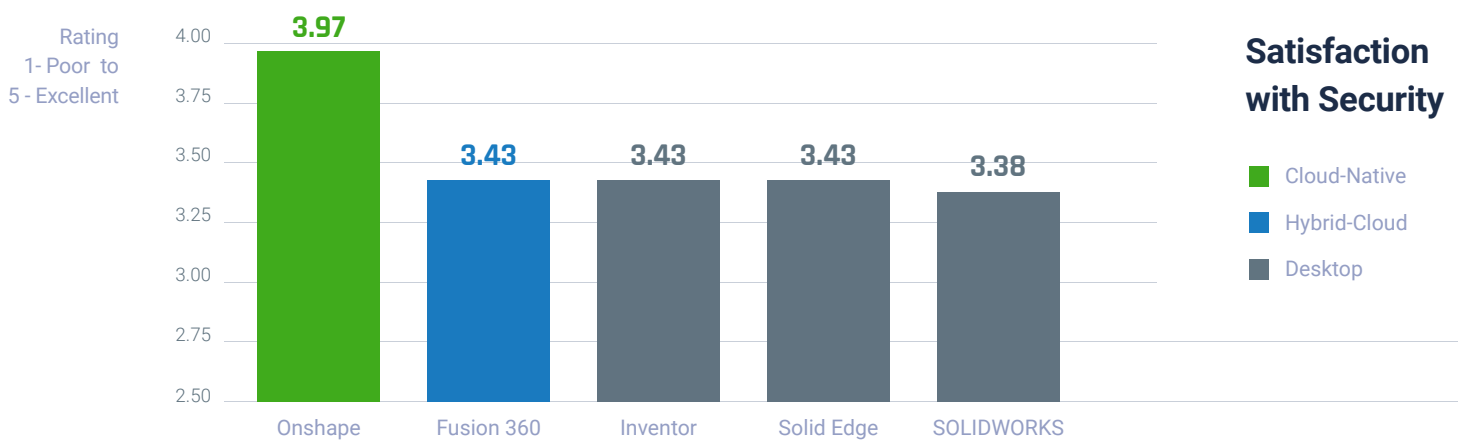

Data security is an underappreciated benefit of cloud-native architectures. With traditional file-based systems, data is “shared” by making copies and emailing those copies around as attachments. It is easy to lose control of sensitive data IP because of the number of copies of files on personal hard drives and thumb-drives, and copies that are sent as email attachments.

In contrast, cloud-native architectures eliminate this security challenge because there is only a single source of design data truth and access is tightly controlled through link sharing and other secure data access measures.

Onshape's cloud-native architecture offers the following benefits:

- *Data can be **accessed directly** by all team members with appropriate permissions set ahead of time and changed instantly as needed.*
- *Data can be **accessed securely** at any time from any device.*
- *Extended team members, suppliers, and even customers can be given **precise access rights** that can even prevent resharing and exporting, and those rights can be enabled or disabled instantly.*

With this level of control, it's no wonder that Onshape users rate the product's security higher than that of other products.

CUSTOMER SERVICE

Cloud solutions can offer collaborative troubleshooting and interactive support sessions, resolving problems much quicker.

For CAD designers, responsive and knowledgeable support teams are important as daily users require resolutions to complex problems in a timely manner to maintain deadlines.

Here’s how the five mainstream CAD platforms compare for customer service:

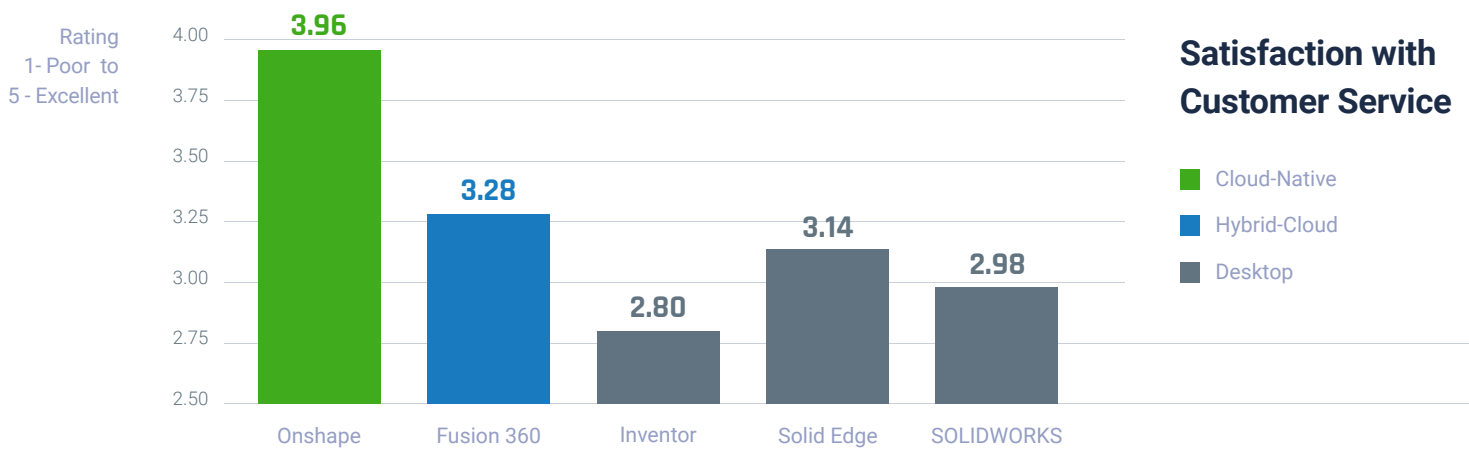

Again, cloud solutions come out on top. Onshape’s customer support agents can resolve issues swiftly by accessing users’ shared workspaces (with permission) to understand their concerns in real time.

When a customer runs into a bug in a traditional CAD product, it is a chore to create support evidence and report it to the vendor. Then there is a telephone tag problem of explaining in words to the CSR how to reproduce the problem starting from opening the file. This problem becomes even worse when multiple companies are involved (such as both the VAR and the CAD vendor).

And after the user goes through all that trouble, it still may take many months or years before a fix is received – or the problem may never be resolved. In many cases, CAD users find the burden of reporting a bug (and how to reproduce it) not worth the effort and time it requires relative to the likelihood of getting their issue resolved.

How does a cloud-native architecture change this dynamic? Here are Onshape's five major customer service advantages over hybrid-cloud and desktop products:

- 1 Microversions:** Data is stored incrementally in microversions as work is done and any state can be restored. This means that a Customer Service Representative (CSR) can always immediately get to an exact reproducible case for a reported issue (providing the customer grants them access). Onshape also provides the user with a built-in issue reporting tool that tells the CSR the exact microversion where the issue occurs and allows the user to create a screenshot and annotate the issue.

 - 2 Branching:** Onshape has non-destructive branching that allows the CSR to create a branch at the moment the issue occurred to debug the problem, while the user can continue working on their main branch (assuming the user provides the CSR access).

 - 3 Collaborative Troubleshooting:** If needed, the Onshape CSR and the user can have a joint collaborative session within Onshape where:
 - The user can show the CSR the problem in more detail.
 - The CSR can show the user a workaround on the actual data.

 - 4 CSR Access to Onshape Developers:** The CSR can further share the debugging branch with an Onshape developer to work directly on the problem and can communicate directly with the developer in product.

 - 5 Speedy Upgrades in the Cloud:** A fix can be delivered immediately without waiting for a service pack and without requiring any action from the user. That fix is then automatically available to all Onshape customers as well.
-

CAD performance and tech support aside, customer sentiment is always influenced by cost and their feelings about their return on investment. We asked product design professionals how satisfied they are with the "Price/Value" of their CAD product.

PRICE / VALUE

Newer cloud products are recognized for better price and value.

Product design teams rely heavily on their tools. Any investment or change in CAD software directly impacts daily operations, making teams very sensitive to price-value returns. The cloud has introduced subscription pricing, allowing users to access professional CAD and PDM without the upfront costs of purchasing software outright.

This business model shift not only broadens access, but also ensures that users receive continuous updates and improvements, maximizing value for their investment.

Here’s how the five mainstream CAD platforms compare for price/value:

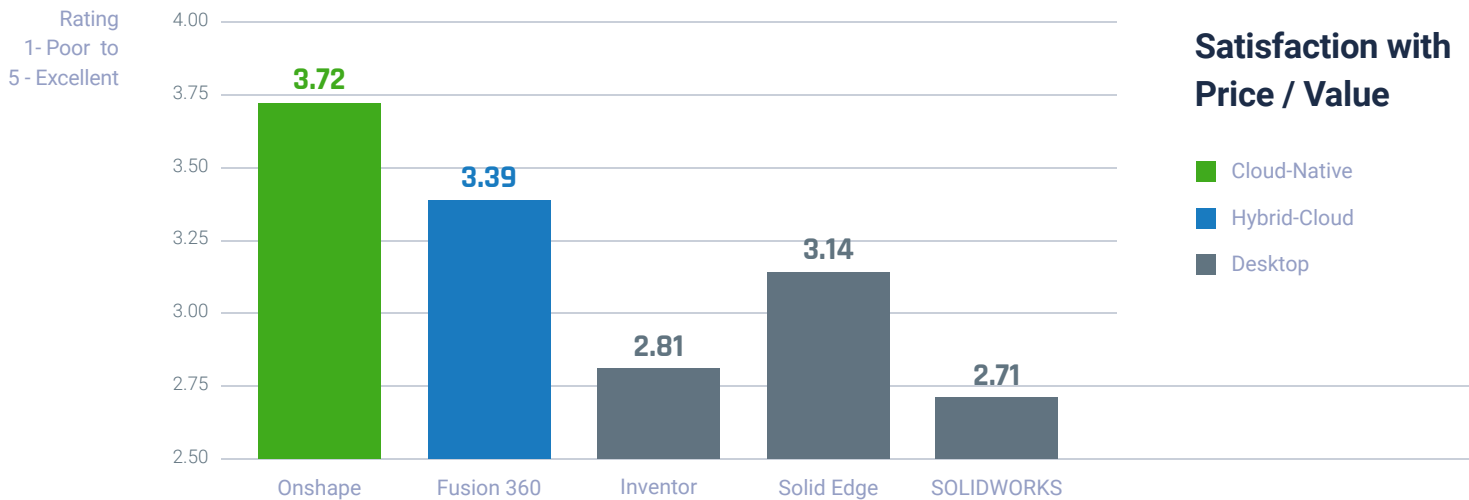

All three desktop products (SOLIDWORKS, Inventor and Solid Edge) trail the newer products (Onshape and Fusion 360) in customer price/value ratings. And while Fusion 360 is substantially cheaper than its four competitors – SOLIDWORKS costs 4 to 8 times more and Onshape costs 3 to 5 times more – it still trails Onshape in satisfaction with price/value.

As with purchasing furniture or automobiles, the lowest price does not always correlate with the best value.



Why does Onshape have the highest NPS and Product Satisfaction scores in the mainstream CAD market?

As we explored earlier in this report, the [Net Promoter Score](#) (NPS), is the predominant customer satisfaction measure used across many industries. The metric indicates how likely a customer is to recommend a product or service to a colleague or friend.

NPS Scores by CAD Architecture

- Onshape
- Fusion 360
- SOLIDWORKS, Solid Edge, Inventor

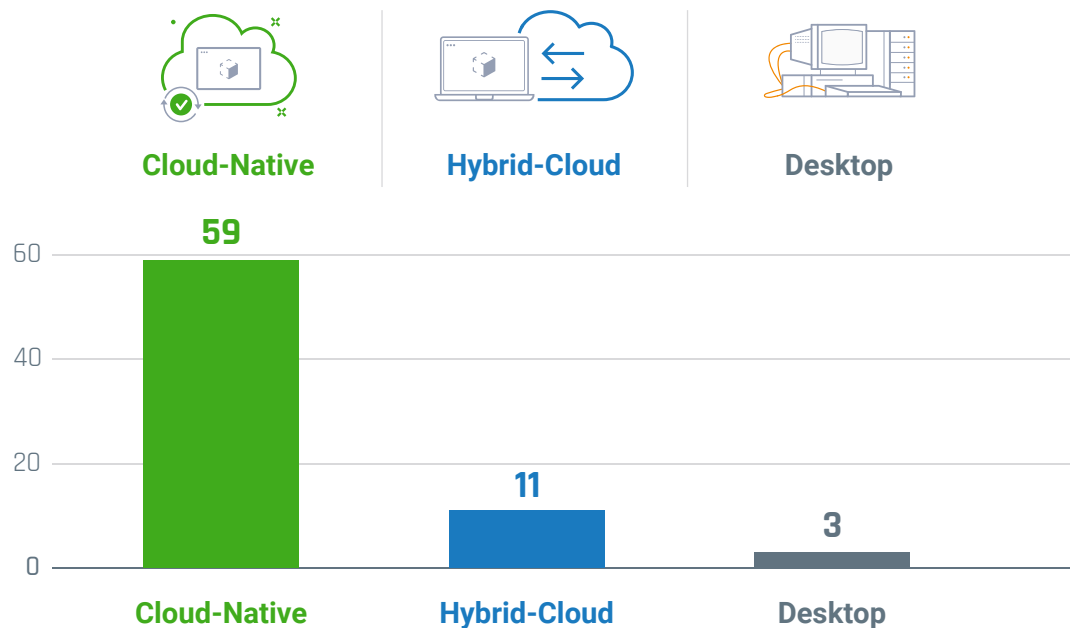

Cloud-native CAD solutions, and Onshape in particular, receive much higher NPS and product satisfaction scores than older desktop products across all areas measured. Onshape’s high customer loyalty marks are recognized by independent review sites like [G2](#) and [TrustRadius](#).

Onshape makes people more productive and teams more efficient because its cloud-native architecture is able to resolve the specific time-wasting issues and concerns discussed in [Insight #1](#).

Conversely, hybrid-cloud Fusion 360 has a lower NPS score closer to the three desktop products. This likely is because Fusion 360 is architecturally closer to desktop software. It still uses files to store design data and lacks many of the distinct advantages that a cloud-native architecture provides.

Probing for reasons behind a positive or negative NPS score, we also asked product development professionals to rate their satisfaction in 10 different product areas.



- FUNCTIONALITY
- RATE OF SOFTWARE UPGRADES
- PRICE / VALUE
- RELIABILITY
- COLLABORATION
- ACCESSIBILITY
- SECURITY
- ADMINISTRATION
- CUSTOMER SERVICE
- CRASHES AND DATA LOSS

While Fusion 360 and the three desktop solutions (SOLIDWORKS, Solid Edge, and Inventor) have mostly similar scores on the 10 product areas rated, it is notable that mainstream market leader SOLIDWORKS comes in last for 8 of them.

Perhaps this is why more SOLIDWORKS users are deciding to switch to newer cloud-native products? (See [Insight #2.](#))

Satisfaction with CAD and PDM in the Mainstream Market

Percentage of Respondents choosing 4-5 (Good or Excellent)

■ Desktop (SOLIDWORKS, Solid Edge, Inventor) ■ Hybrid-Cloud (Fusion 360) ■ Cloud-Native (Onshape)

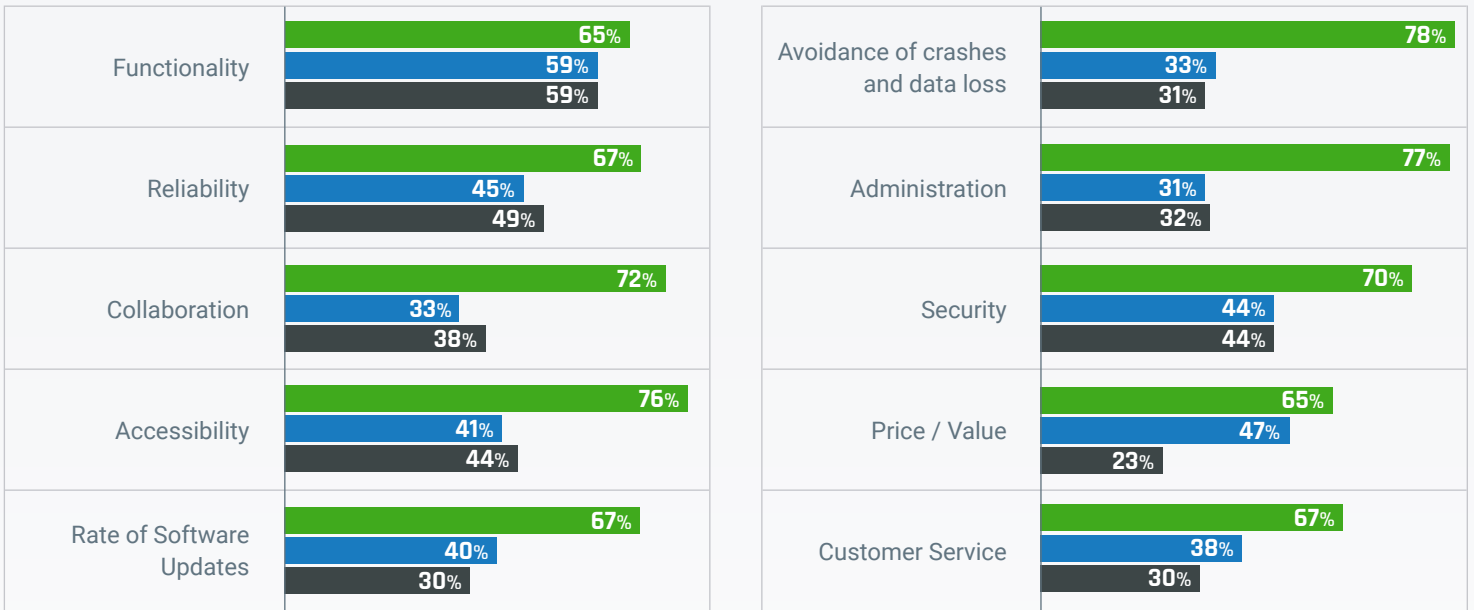

Satisfaction ratings of 701 CAD users

Cloud-native Onshape scores first in all 10 categories.

Product design professionals using cloud-native PDM are much more satisfied than those using separate file-based CAD and PDM solutions

There are major differences in functionality between the most heavily used data management solutions in the mainstream CAD market (such as SOLIDWORKS PDM and Autodesk Vault) and process-centric PLM solutions such as Windchill and Teamcenter. For the purposes of this report, we will focus on the mainstream PDM solutions most often used with mainstream CAD products.

Traditionally, mainstream PDM solutions have served two major functions:













- **Process Management** – Supporting a release and approval process for design and manufacturing.
- **Data Management** – Securing and storing files, managing access and editing, and managing the references between files.

While process management is what PDM vendors like to talk about most, many companies buy PDM to deal with more basic data management issues like secure backups and resolving problems caused by moving and renaming files.

In other words, mainstream PDM is bought first and foremost to reduce accidents that are common when CAD users deal directly with files.

Reducing errors is one of the biggest fundamental advantages of a cloud-native PDM architecture. In a cloud-native PDM solution, data is not stored in files that are then manually copied to a file-based vault. Instead, all data is automatically stored in small increments in a secure cloud database. To make it easy for users, there is no “Save” button required as all data is saved incrementally in microversions.

The architecture of a PDM system depends not only on its own implementation, but also on the storage methodology of the CAD data it manages.

	How is data stored?	Where is data stored?	Is PDM built-in?
 Cloud-Native	 Cloud Database	 Cloud	 Yes
 Hybrid-Cloud	 Files	 Cloud	 No
 Desktop	 Files	 Servers	 No

Architecturally, these CAD and PDM product combinations can be classified as:

- **Cloud-Native** – CAD and PDM run in the cloud and store data in a multi-user cloud database.
- **Hybrid-Cloud** – CAD runs locally, PDM runs in the cloud, data is stored in local files that are copied to the cloud.
- **Traditional Desktop** – CAD and PDM run locally and store data in local files that are copied to servers.

Below are the most common PDM systems for four of the mainstream CAD products:

	CAD	PDM
Cloud-Native	Onshape	Onshape
Hybrid-Cloud	Fusion 360	Fusion 360 Manage with Upchain
	SOLIDWORKS	Collaborative Designer for SOLIDWORKS
Traditional Desktop	Inventor	Autodesk Vault
	SOLIDWORKS	SOLIDWORKS PDM
	SOLIDWORKS	SOLIDWORKS Manage

Note: Solid Edge had fewer than five respondents that said they used PDM, so it has been excluded from this PDM analysis.

Let's look at the architectural underpinnings of these CAD and PDM combinations in more detail.

Cloud-Native



Onshape embeds data management directly in the CAD product. It manages and stores data directly in a multi-user cloud database. Prioritizing foundational elements like cloud infrastructure, scalability, security, and data management before layering on functionality has allowed Onshape to address the needs of modern design teams.

Hybrid-Cloud



Fusion Manage with Upchain and Collaborative Designer for SOLIDWORKS both run in the cloud and are accessed through a browser. However, they manage files produced by desktop CAD or hybrid-cloud CAD products that are first stored on the desktop. They are also separate add-ons with separate user experiences.

Traditional Desktop



SOLIDWORKS PDM, SOLIDWORKS Manage, and Autodesk Vault are all traditional installed PDM products with customer maintained servers that manage files. They are separate add-ons with separate user experiences.

Of the five mainstream CAD products, only Onshape provides built-in data management.

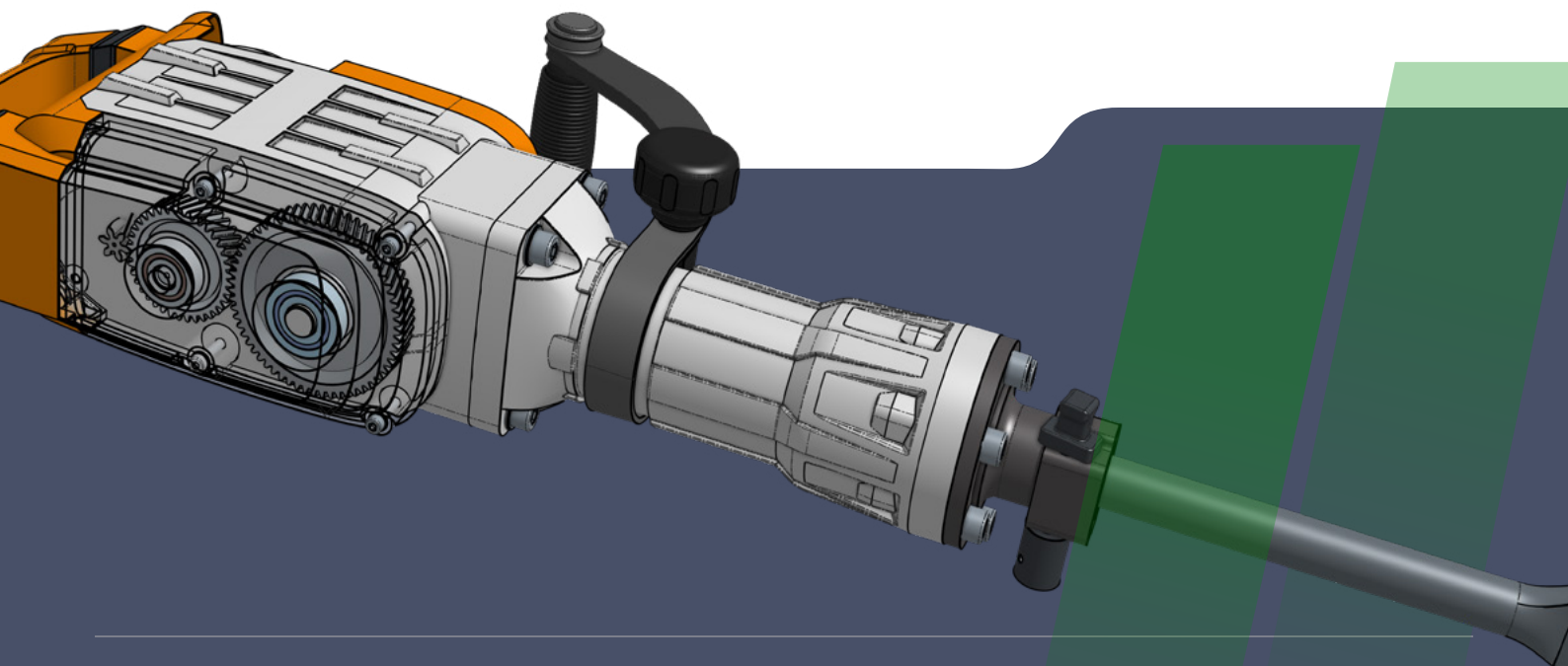



Why does Onshape have the highest NPS and Product Satisfaction scores in the mainstream CAD market?

DATA MANAGEMENT

Newer cloud products, specifically cloud-native Onshape, have surpassed desktop products and hybrid-cloud products in terms of user satisfaction with data management.

CAD teams generate a vast amount of information, ranging from different design iterations to associated documentation. Managing the sheer volume, across teams and time zones is a major challenge, especially when ensuring that everyone accesses the most recent version. When data is not organized or managed effectively, there are direct impacts on productivity and overall project timelines.

Respondents were asked to rate the data management of their CAD system regardless of whether they said they used PDM or not.

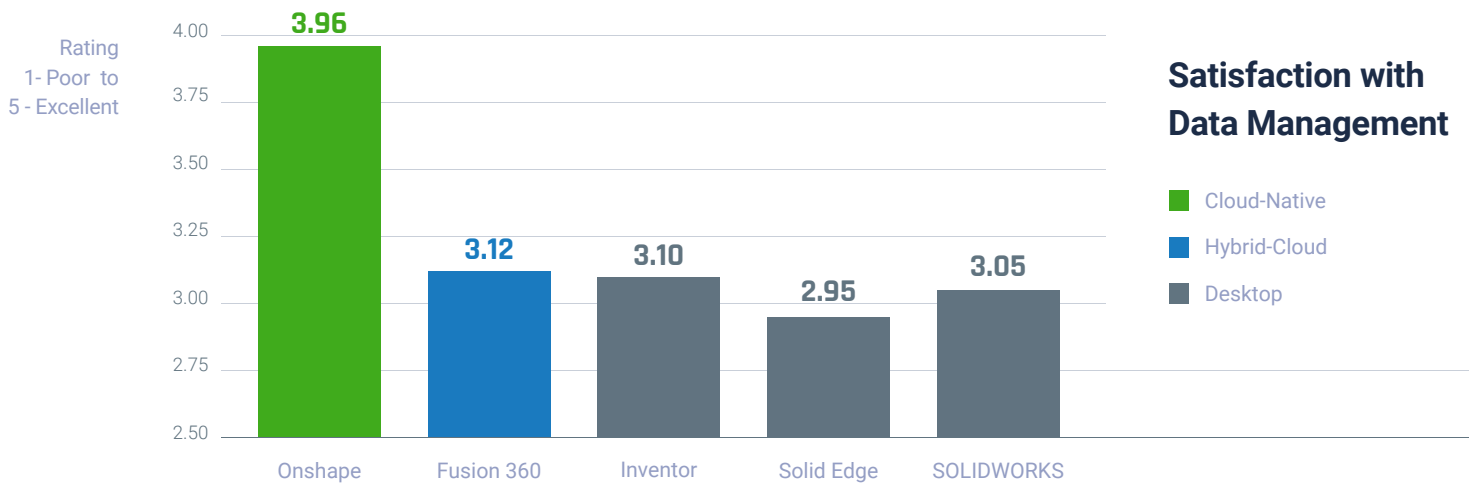

Cloud-native Onshape users are again the most satisfied by a wide margin. And again, there is little difference between the hybrid-cloud solution (Fusion 360) and desktop solutions (SOLIDWORKS, Inventor, and Solid Edge).

This may be because in Onshape, data management is built in so users inherently get the basic data management benefits of a traditional PDM system without the added costs and complexity. Onshape users who don't use PDM for release management are still getting benefits like built-in backups, access to their full edit history and the ability to revert back to any prior stage of the design.

More Onshape users also said they use PDM than any of the other products, likely because PDM is built into the same user interface. Smaller product development teams (1-5 people) were less likely than larger teams to say they use PDM, possibly seeing less of a need with fewer people collaborating. They may also find traditional PDM solutions complex, costly, and time consuming.

Users of Fusion 360 were by far the least likely to use PDM, probably because they tend to be in smaller teams.

Who Uses PDM?

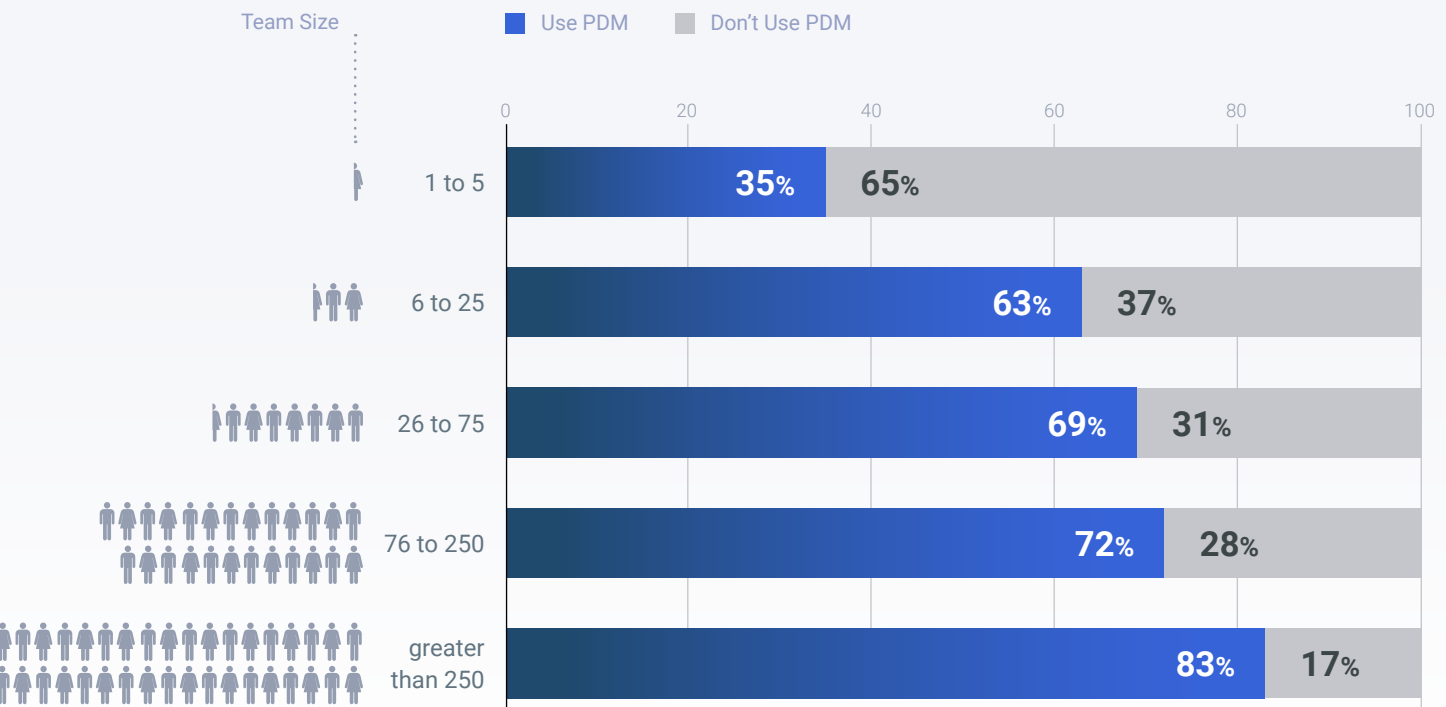

With six or more people involved in a design process, data management enhances collaboration by ensuring organized, accessible, and reliable information is exchanged among the team.

For teams of six or more, over 75% of respondents indicated they need PDM, though much fewer actually use it.



Why Don't Some Engineers Use a PDM System?

This is a complex topic. To better understand, we asked respondents who don't use a PDM to select reasons why. Cost, complexity, and maintenance were the major blockers. Let's take a look at the data.

Reasons for Not Using PDM

50%
said it was "Too Expensive"

42%
said it was "Too Complicated" or "Needs too Much Maintenance"



In summary, many respondents want the functionality that PDM provides, but either can't afford it or think its problems outweigh its benefits.

Those are the opinions of respondents that do not use PDM. Let's explore the perspectives of those who do use it.

More than half of the respondents using the most common mainstream CAD products also use PDM.

The breakdown by product is:

PDM Usage by CAD Platform

■ Use PDM
■ Don't Use PDM

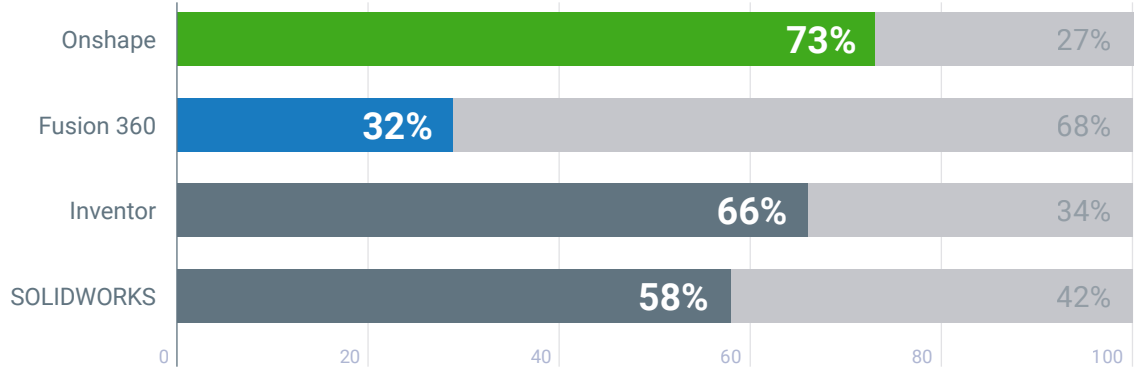

These PDM users were then asked how likely they were to recommend their primary PDM system to others, the core question determining the NPS customer loyalty score. The results were surprising.

NPS Scores by PDM Product

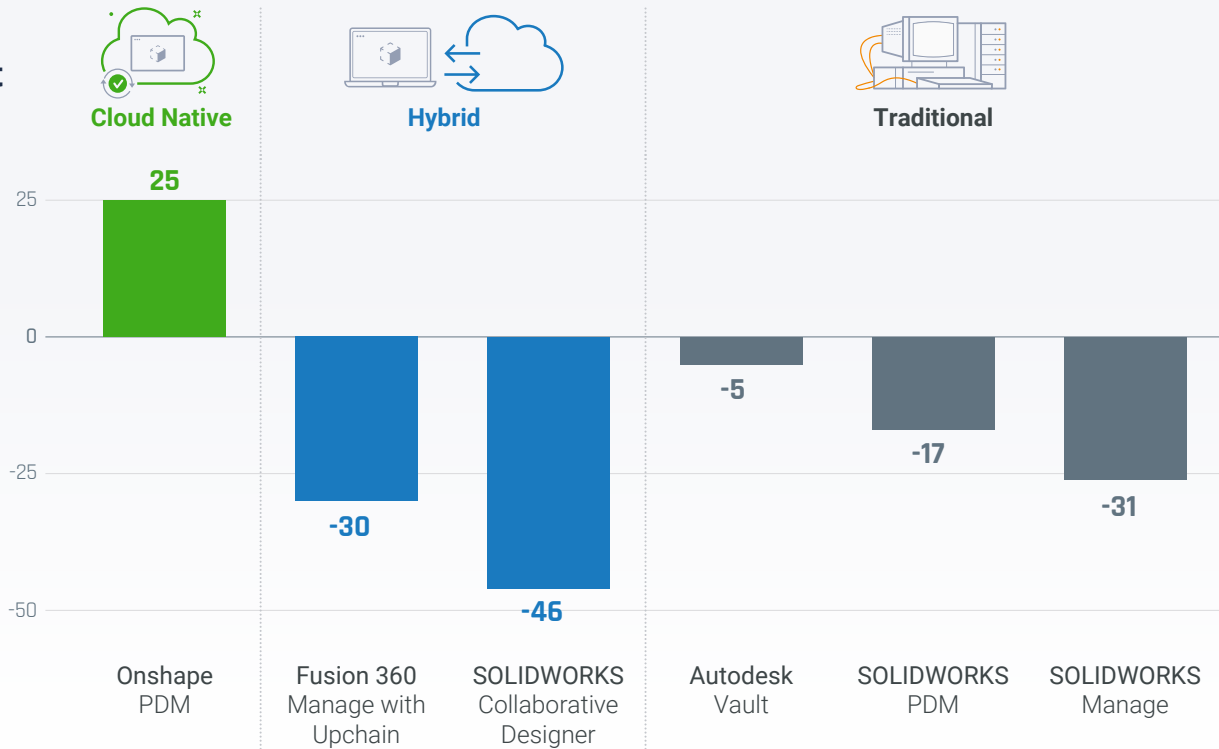

Only users of cloud-native CAD software are likely to recommend their PDM solution to others.

Average NPS scores below zero are not common across all industries.

The consistent dissatisfaction is likely connected to frustration with the limitations of hybrid-cloud and traditional desktop software.

It is also worth noting that among SOLIDWORKS users, traditional SOLIDWORKS PDM is rated much higher (-17) than SOLIDWORKS' newest 3DX-based cloud product, Collaborative Designer for SOLIDWORKS (-46).

Why is cloud-native Onshape's PDM rated so much higher than its competitors? Here are four possible reasons:

- 1 No Files** – For traditional desktop and hybrid-cloud PDM systems, most of the data management headaches are really problems with managing files, protecting files, backing up files, and keeping track of relationships between files as they are edited in various ways. Those problems are eliminated when files are not the primary storage mechanism.
- 2 Built-In Data Management** – Onshape's data management is built into the user interface. CAD and PDM are not two separate products with two separate installation processes and user experiences as with other vendors. Because data management is built into Onshape, many workflows that slow down or are disruptive to the design process are eliminated.
- 3 Collaboration** – In product development, effective collaboration and accessibility are paramount. Onshape stands out by offering intuitive tools like View, Markup, and Chat, allowing stakeholders to engage with both static and real-time evolving design data. Unlike other systems that require check-in/check-out procedures and limit viewing to frozen PDM versions, Onshape promotes agile design by enabling real-time feedback and adjustments.
- 4 Mobile** – Recognizing the ubiquity of mobile devices in today's world and especially among extended team members, Onshape ensures PDM functionality across all devices, from smartphones to tablets, ensuring uninterrupted access and efficiency in any work scenario.

Onshape's PDM would not have better NPS ratings if it didn't overcome the challenges users identified, including complexity and added cost. Due to Onshape's unique cloud-native architecture, hassles like locating the right data, version control issues, data duplication, and the need to wait for files to be checked in or out are eliminated.

In Onshape, multiple team members are never blocked from access to the CAD data, can work concurrently on the same project, and can see design updates in real time – reducing the risk of accidentally overwriting each other's work.

A high NPS score for PDM, reflecting a willingness to recommend, is a testament to Onshape PDM's impact on its users' day-to-day experiences.

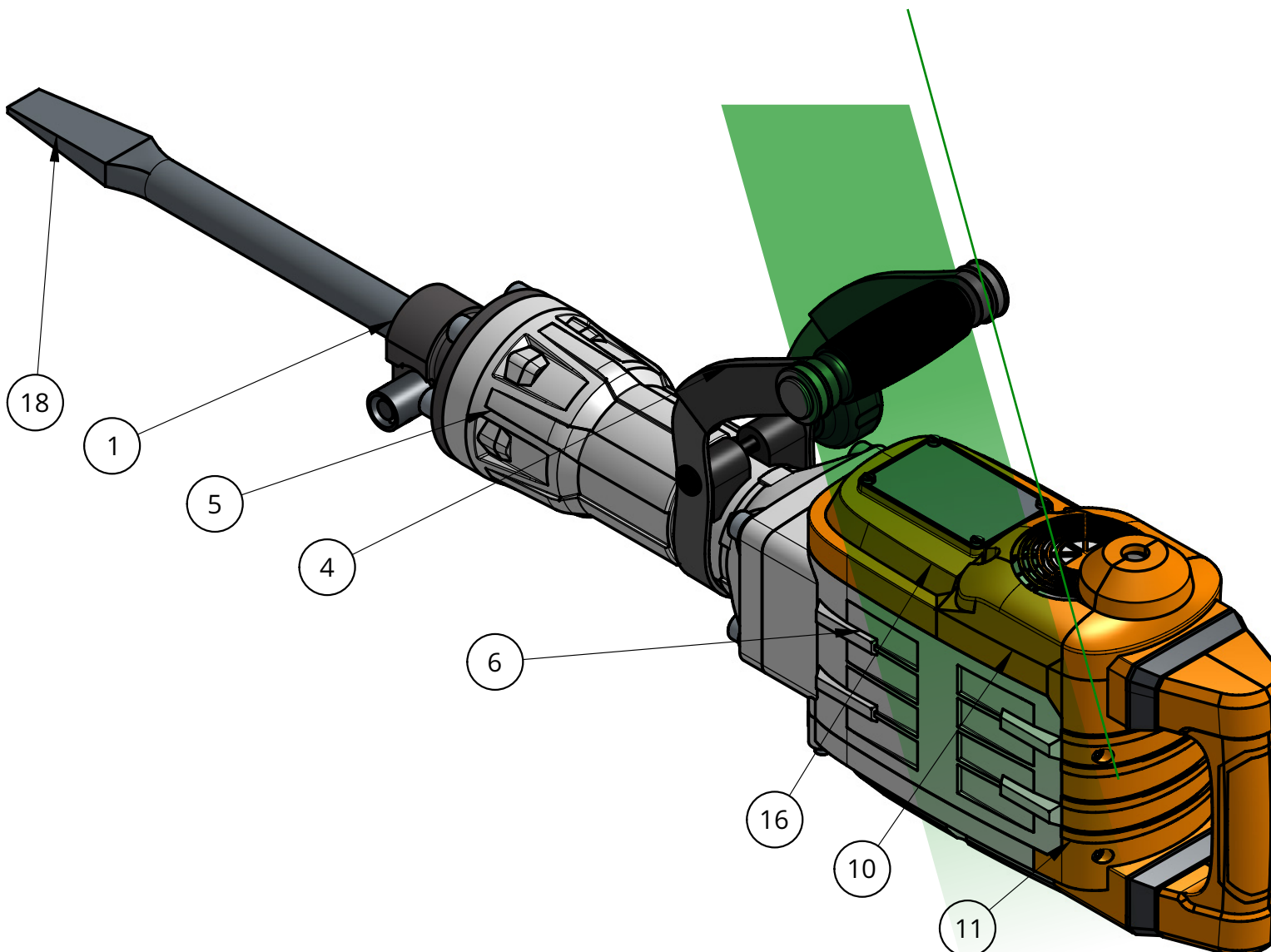

Why Wait Another Day to Get the Benefits of Cloud-Native CAD & PDM?

Your early-career professionals and new hires out of engineering school grew up in a cloud-enhanced world. They demand access to the latest information immediately – and they're accustomed to getting it in both their personal and professional lives. So the idea of using archaic product development tools that slow them down is ludicrous to them.

Indeed, it is ludicrous for engineering and manufacturing teams to stick to technologies they know have [built-in bottlenecks](#) blocking their design process.

In this report, you read about how engineering teams said they were losing 7.1 hours a week – **28.4 hours a month** – to frustrating delays related to their CAD and PDM software.

Here were the top reasons for the workflow interruptions:

- 1 Locating the correct design data when you need it.
- 2 Time lost to CAD software crashes, recreating lost work, file corruption, etc.
- 3 Inability or difficulty when working remotely on design data.
- 4 Preventing data loss, backing up or restoring design data.
- 5 Delays and file access issues, such as locked files, PDM check-in/out or uploading and downloading data.
- 6 Working on the wrong version of design data.
- 7 CAD software version compatibility issues.

Only cloud-native CAD and PDM platforms fully eliminate these issues. At the core of all the aforementioned problems is a file-based architecture, which is extremely vulnerable to crashes and data corruption, and limits real-time communication and collaboration.

Cloud-native CAD accelerates every stage of the product development process. Everyone on the team is always looking at the same single source of truth. Onboarding new hires takes minutes versus days or weeks to secure CAD licenses. Internal company stakeholders, such as executives or marketers, can access designs and provide feedback earlier – ultimately leading to better products.

With cloud-native PDM, version control confusion is a thing of the past. Whenever an engineer makes a design change, everyone else on the team can instantly see it. A comprehensive Edit History tracks every change, allowing users to quickly return to any prior state of the design if desired. Having built-in PDM dramatically reduces the chances of manufacturing the wrong part. Not having to worry about version control frees up engineers' mindshare, allowing them to focus more on improving their designs

Every CAD vendor is now on the cloud bandwagon, prominently featuring "cloud" in their marketing and advertising. But beware: "cloud-based" and "hybrid-cloud" are [not the same thing](#) as "cloud-native" and don't deliver the same benefits. Don't be fooled.

Most cloud-advertised products are really traditional desktop CAD systems at their core, still based on copying files, and just storing them in the cloud. They are still extremely vulnerable to crashes and data corruption. Team members using partial-cloud solutions cannot be confident they are looking at the latest version of a design.

Having everyone on your product development team being able to access the latest data when they need it, and to work uninterrupted by software bottlenecks, is paramount for accelerating your time-to-market.

Cloud-native Onshape is the only product development platform today that eliminates all the productivity bottlenecks explored in this report. Competitors can't offer the same benefits right now because they are all selling cloud-storage solutions masquerading as cloud-native ones.

In the next section, we'll visit a leading hydrogen energy company that credits Onshape's built-in PDM and real-time collaboration tools for increasing its productivity by 10X.

[TRY ONSHAPE NOW >](#)

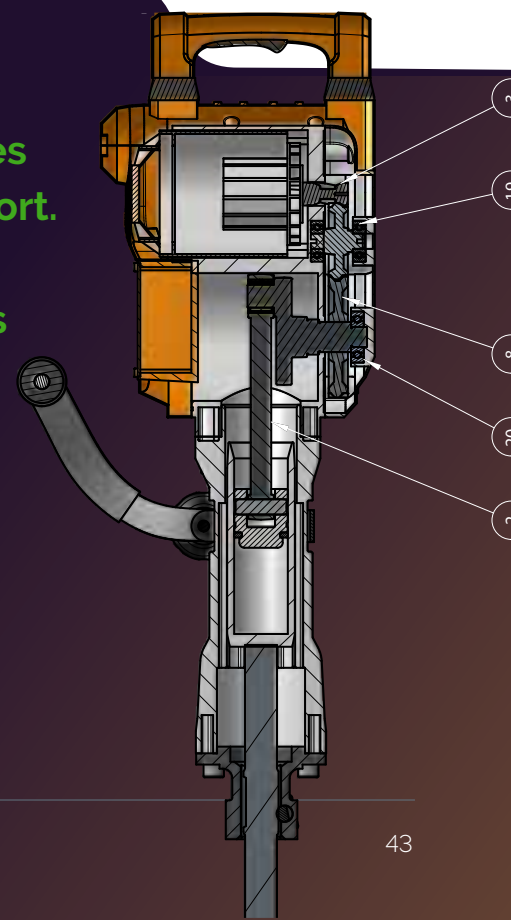

HOW ONSHAPE HELPED A LEADING HYDROGEN ENERGY COMPANY SPEED UP PRODUCT DEVELOPMENT BY 10X

To design its hydrogen-on-demand generators, GenCell uses cloud-native Onshape for its built-in version control and real-time collaboration tools.

CUSTOMER STORY



Industry: ENERGY

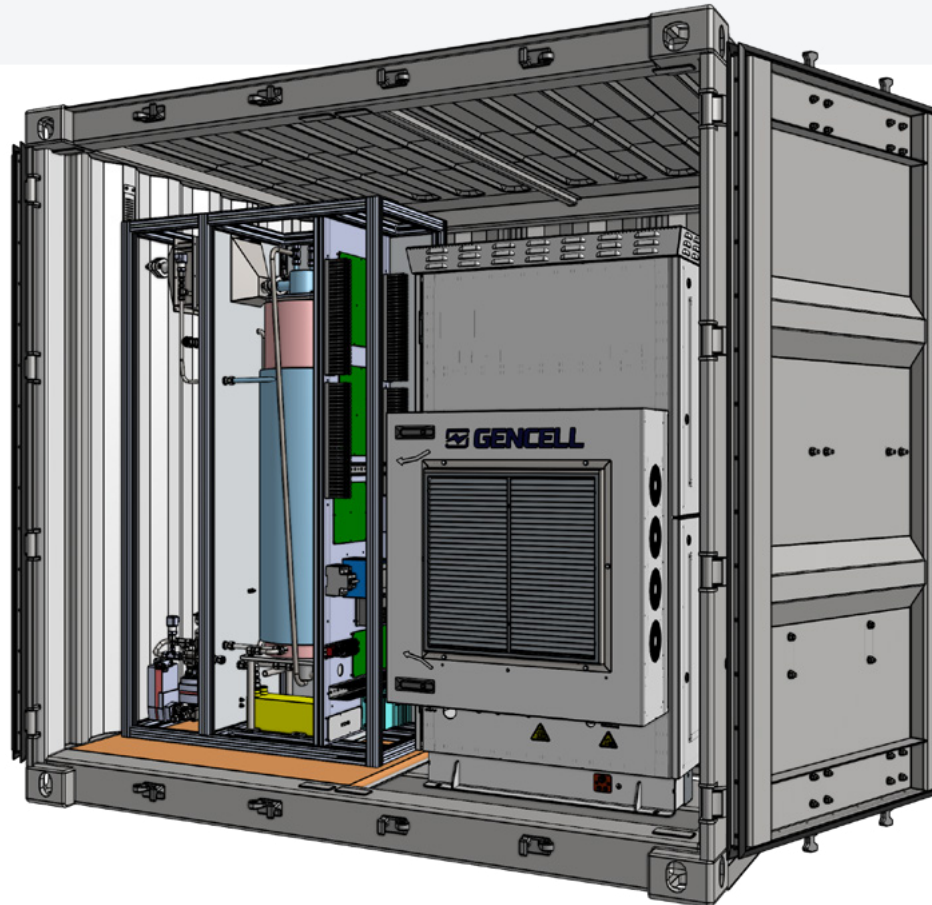

The Challenge

[GenCell](#) is a leading developer of hydrogen fuel cell solutions that provide clean and sustainable energy for the telecom, homeland security, healthcare and utilities industries. Founded in Israel in 2011, the company has grown to over 140 employees and has a worldwide distribution and support network. In 2020, the GenCell engineering team was experiencing significant bottlenecks related to not having a PDM system for version control.

The company estimated it was losing six weeks of work annually due to nearly daily CAD crashes and having to repeatedly fix and debug models. Because the team was working without a PDM system, doing data management manually was prone to human error. GenCell switched from SOLIDWORKS to Onshape in 2022 to accelerate its product development.

Results:

- After switching from SOLIDWORKS, GenCell estimates that cloud-native Onshape has accelerated its product design process by 10X.
- Onshape's automatic version control significantly reduces design and manufacturing errors, eliminating needless material waste and rework.
- Onshape's built-in PDM saved GenCell \$33,000 in upfront software costs vs. purchasing an add-on system, and saved an additional \$70,000 in SOLIDWORKS maintenance fees and required hardware upgrades.
- GenCell no longer experiences CAD crashes, which used to happen almost daily, resulting in decreased productivity.

Jonathan Schwartz, Senior Mechanical Engineer at GenCell, noted that Onshape's built-in PDM was a primary motivation for switching platforms.

"Verifying the data manually to ensure models are up-to-date became a huge issue for us," he recalls. "We were making a lot of errors. Something that happened a lot is we would make an update to a design, but the person ordering the parts would not get the update and would order old parts."

Schwartz says he was frustrated by the amount of time his team was devoting to debugging and fixing CAD models in SOLIDWORKS instead of working on new designs.

"Onshape genuinely makes our lives a lot easier," he says. "I'm a big fan of the platform as it eliminated some crazy headaches for our department, and as a bonus also made our management and finance teams happy because it saved us lots of time and money."

"I'd estimate that Onshape helped speed up our product design process by a factor of 10," Schwartz adds. "Because we no longer have to worry about version control, and now can work together more efficiently with built-in collaboration tools like Comments and Tasks."

[READ THE CASE STUDY](#)

To learn more about how GenCell is leveraging cloud-native Onshape as a competitive edge, read the full case study.

Appendix: Additional Survey Demographics

Who participated in the 2023-24 State of Product Development Survey?

1466

product design and manufacturing professionals including users of more than 14 mainstream CAD, PDM and PLM solutions.

Isurus sourced survey respondents anonymously from two independent sources - [Traceparts](#) and [All3DP](#), and solicited additional responses through direct marketing.

■ Design Team Size

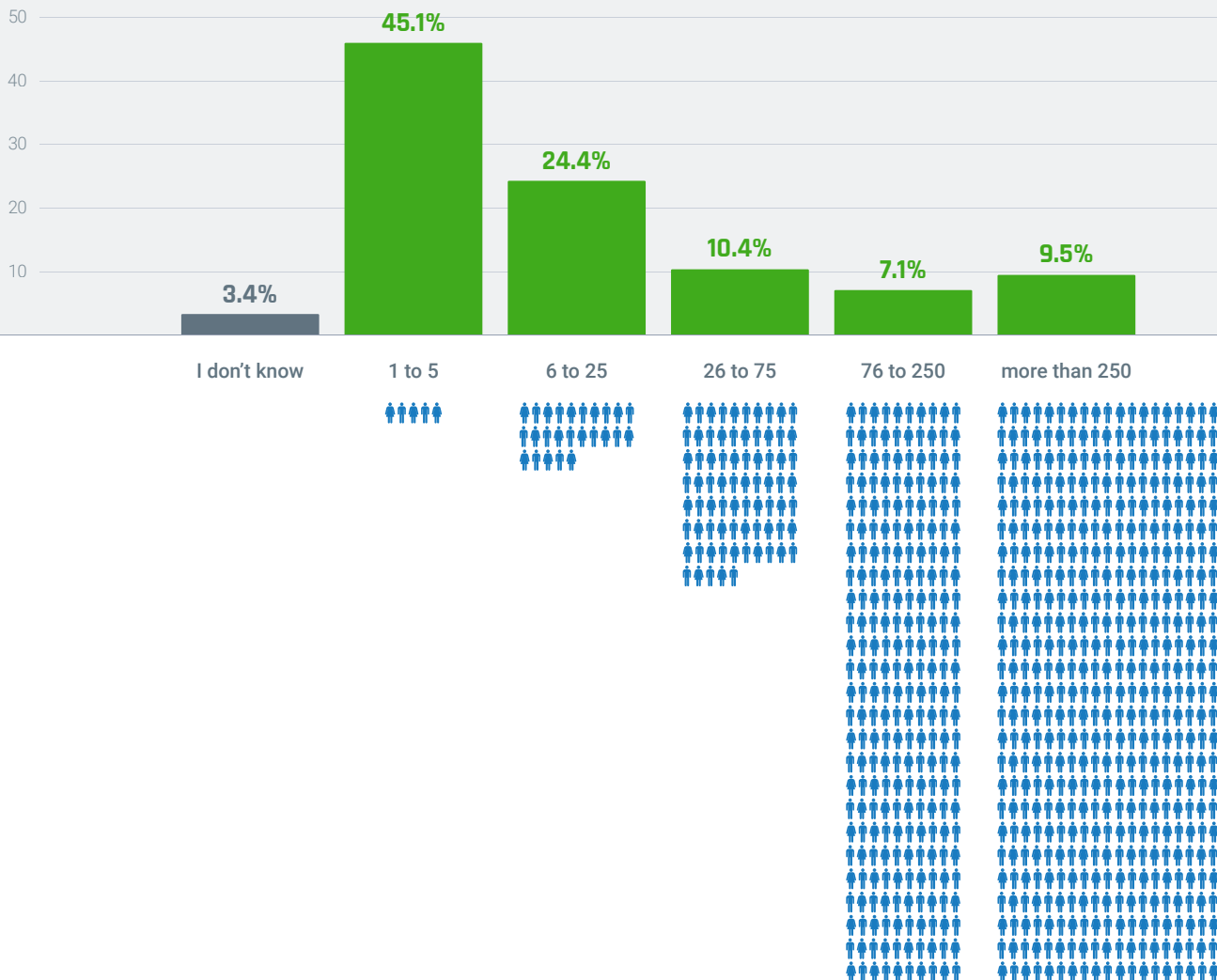

The survey audience best represents the **mainstream CAD market** rather than the process centric market with over 50% of respondents from Design Teams of 6 or more.

- Mainstream CAD market, characterized by professional design teams ranging in size from 1 to 250 but most often with 75 members or less.
- Process centric market, characterized by larger design teams and highly complex manufacturing and supply chains.

Professionals had the following job roles:

■ **Respondents Role**

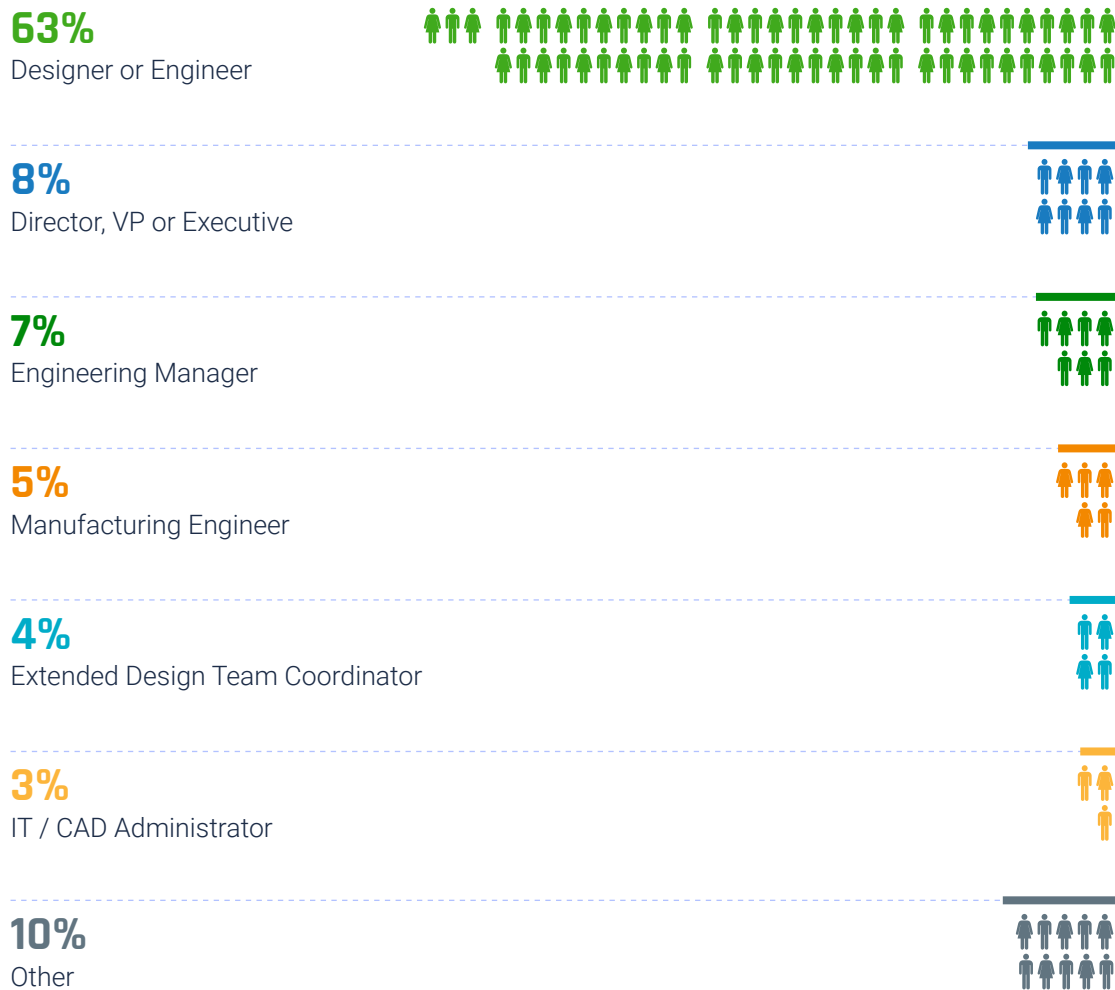

All participants in the survey work for a company that designs or manufactures products, across various industries and company sizes. Nearly all, 90% of respondents, have a direct role in design and engineering.

■ Represented Industries

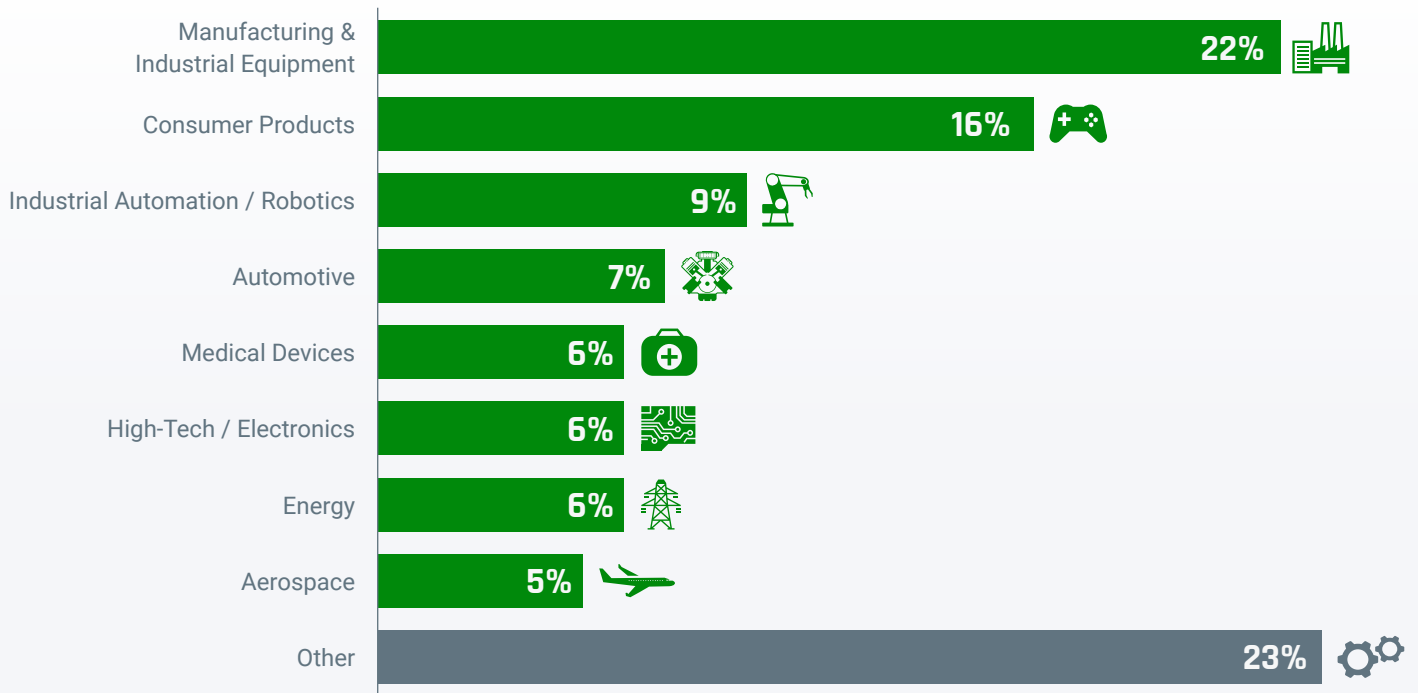

■ Size of Product Development Team

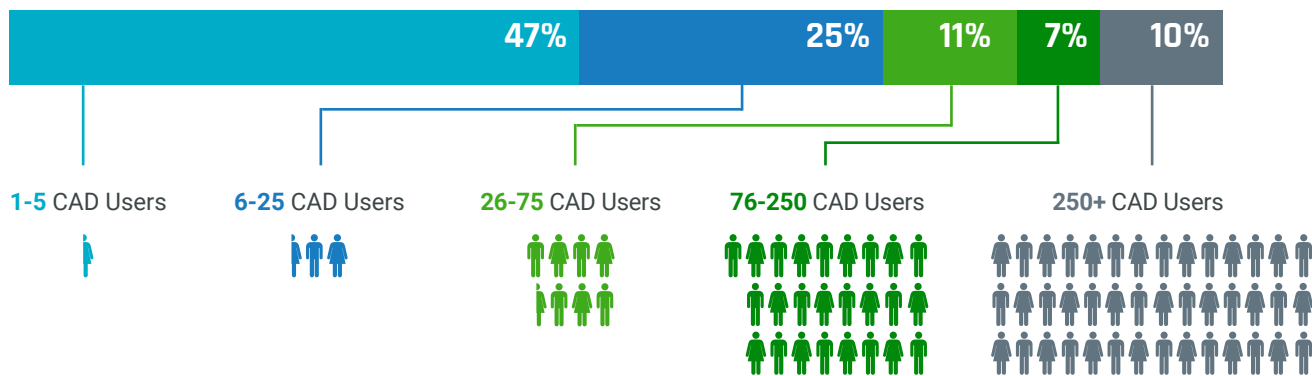

83% of respondents are part of the mainstream market, professional design teams with 75 members or less.

More than half of respondents are daily users of CAD and PDM users.

■ Frequency of CAD Usage

- 64% Daily
- 23% Weekly
- 8% Couple times a month
- 2% Once a month
- 1% Once a quarter
- 2% Less than once a quarter

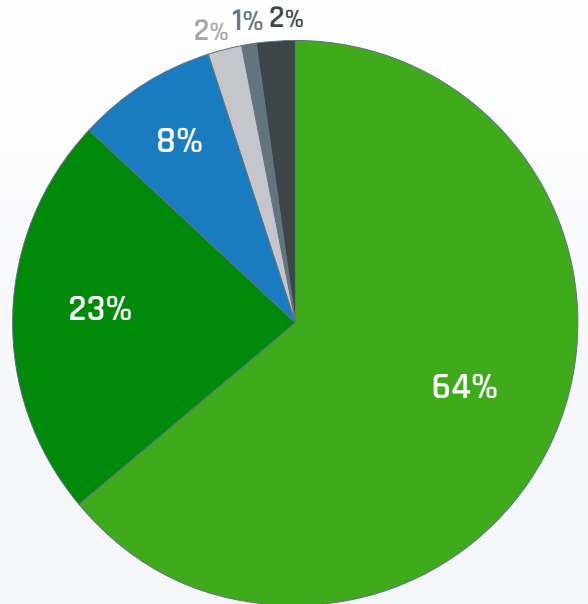

■ Frequency of PDM Usage

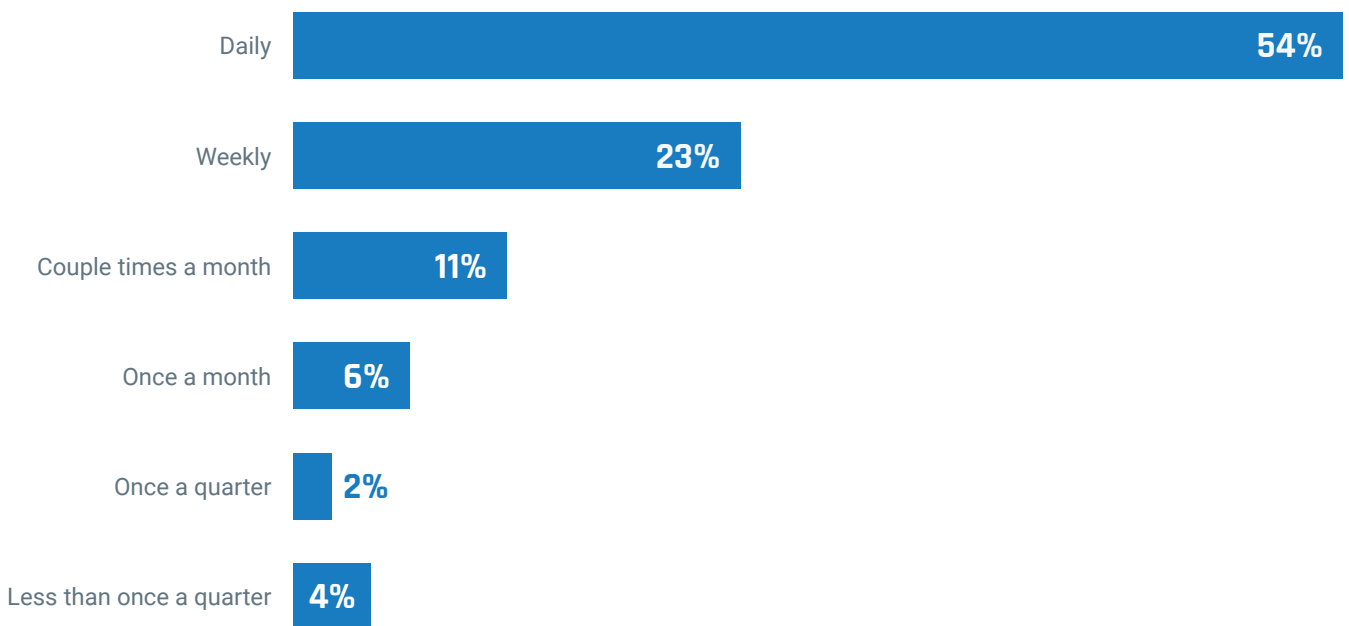

■ Career Experience in Product Development

The survey respondents represented users across all stages of their career with a roughly even distribution between early-mid career < 20 years and late career professionals > 20 years.

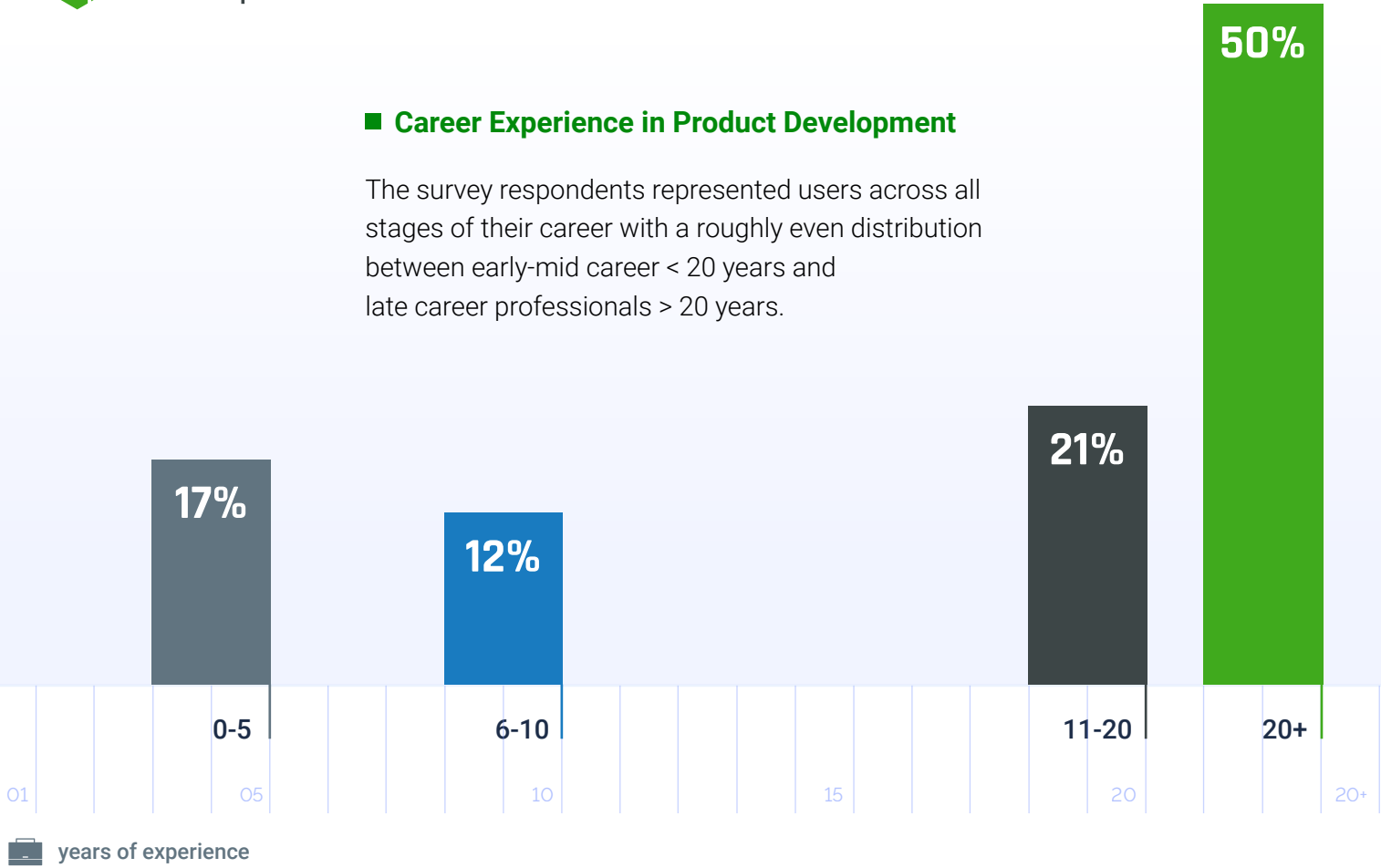

■ Representation of Product Development Software Brands

This survey asked 1466 respondents to name their primary 3D CAD system for professional work. 44% were current or former SOLIDWORKS users.

They broke down as:

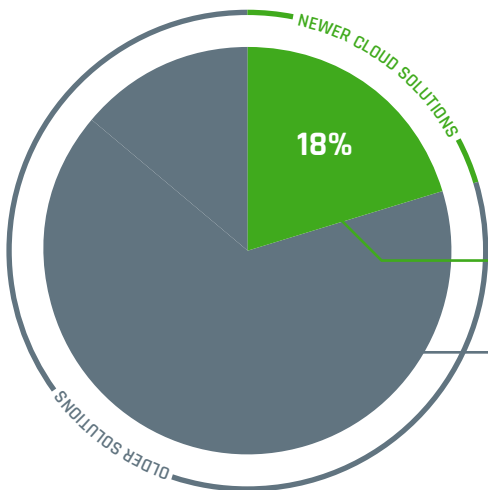

18% Newer mainstream cloud solutions (Onshape, Fusion 360)

58% Older mainstream desktop solutions (SOLIDWORKS, AutoCAD, Solid Edge, Inventor)

12% Process-centric solutions (Creo, NX, Catia)

Other solutions with less than 1.5% respondent share included Rhino (19), FreeCAD (14), Altium (10), Tinkercad (7), Shapr3D (4), 3D Creator (4), 3D Sculptor (2), and SpaceClaim (1).

