



10 Tips to Improve Your Surfacing Skills

An Overview of Surfacing Techniques and Applications



DIGITAL TRANSFORMS PHYSICAL

What is Solid Modeling? What is Surface Modeling?	page 03
Why is Surface Modeling important to modern Product Design?	page 04
1. Create a Wireframe of your product	page 05
2. Use Rendering to visualize your product before it's manufactured	page 06
3. Use reference images when defining your Wireframe	page 07
4. Using Splines and Bezier Curves	page 08
5. Know the basics of creating a Loft	page 09
6. Create 3D Curves to use as guides	page 11
7. Understand Curvature Continuity	page 12
8. Conduct a Surface Analysis using Zebra, Curvature and Surface Continuity	page 13
9. Iterate quickly with the "Branching and Merging" functionality	page 14
10. Parametrically drive Surface Design	page 15
Design Better with Cloud-Native CAD	page 16
Final Thoughts	page 17

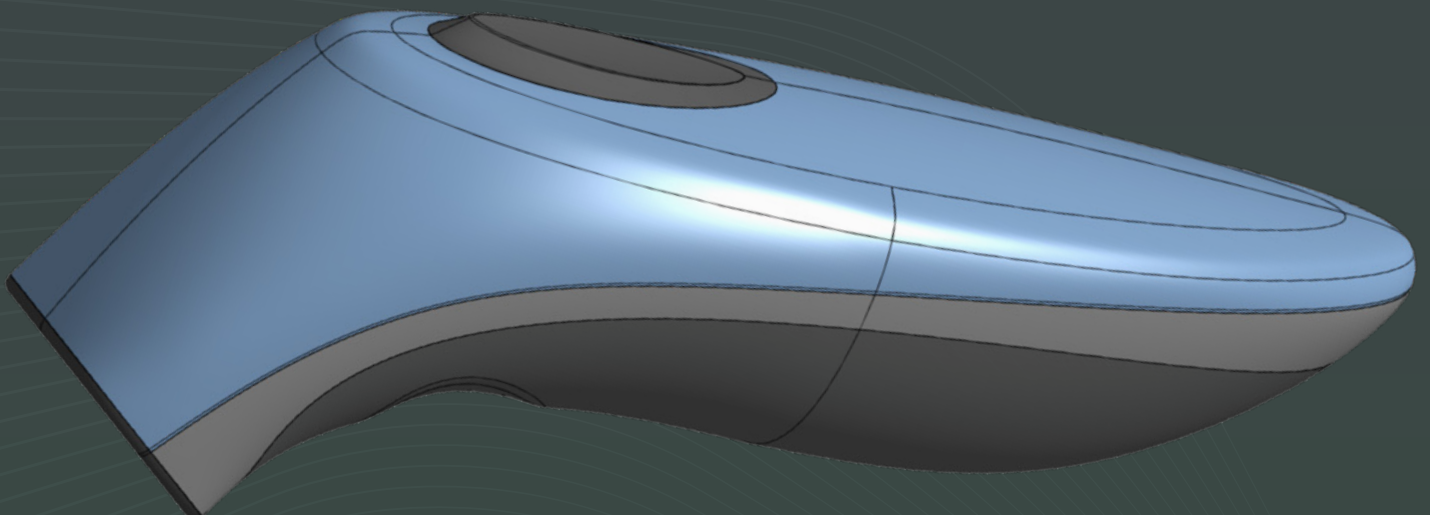

What is Solid Modeling?

Solid modeling works by manipulating and combining multiple blocks into 3D shapes with volume or thickness. CAD designers can create objects, leveraging 2D and 3D geometries, such as: 2D sketches or 3D primitive shapes like cubes, spheres, cones, etc. Because Solid modeling is limited to only creating objects that have thickness, this method of design can only take your products so far.

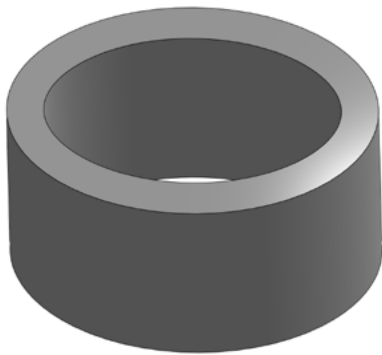

Solid Modeling

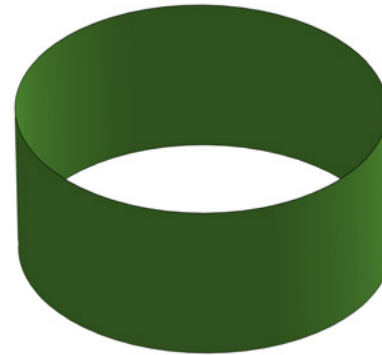

Surface Modeling

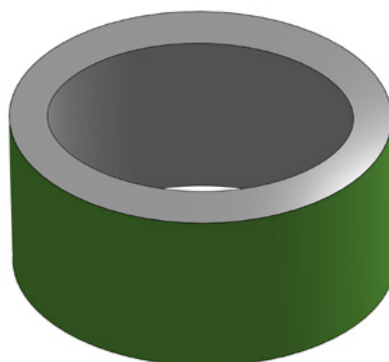

Solid Model with Exterior Surface Highlighted

What is Surface Modeling?

Surface modeling focuses on the external characteristics of an object. Using 3D curves, the designer generates an object by extending a surface over it. To put it simply, the limits of the object's boundaries are being defined. This method of modeling allows designers to control the surface curvature, edges and styling of a product's outer form.

Why is Surface Modeling important to modern Product Design?

Great businesses understand that prioritizing design increases chances of a product's success. A well-designed product delights customers, sets you apart from the competition, and increases sales.

Steven Bradley, author of *Design Fundamentals*, claims that individuals have a biological predisposition for objects that are beautiful. He further states that:

"Human beings have an attractiveness bias; we perceive beautiful things as being better, regardless of whether they actually are better. All else being equal, we prefer beautiful things, and we believe beautiful things function better. As in nature, function can follow form."

With a pen and paper, designers can create the most aesthetically-pleasing product; however, this leads to the common mistake of designing something that's impossible to manufacture at scale. Fortunately, surfacing in CAD allows designers to leverage production and manufacturing tools, preventing form from dictating (or even limiting) function. This approach to modeling allows a designer to create more freeform shapes with an unparalleled level of detail and realism. In fact, surface modeling is required for sophisticated modeling approaches such as hybrid modeling, in which designers combine solid and surface modeling techniques.

If you are dealing with CAD imports such as (STEP, IGS), surface modeling allows you to work smoothly and make changes to solids without a CAD Feature Tree with ease. In short, surface modeling allows designers to compensate for the limitations of solid modeling techniques.

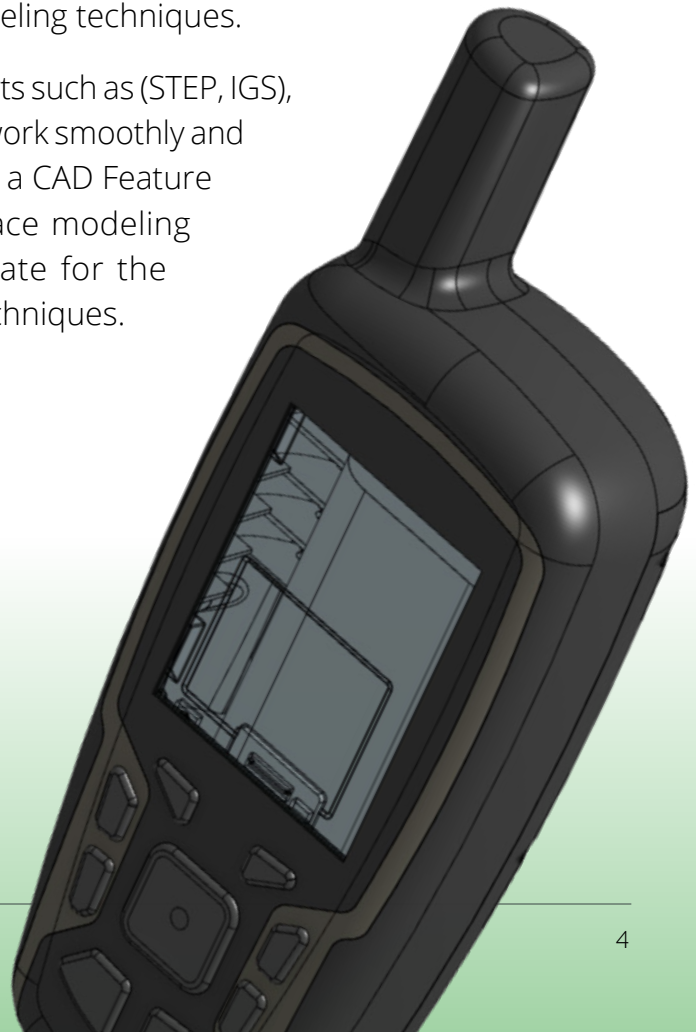

Here are 10 tips to improve your surfacing skills:

1 Create a Wireframe of your product

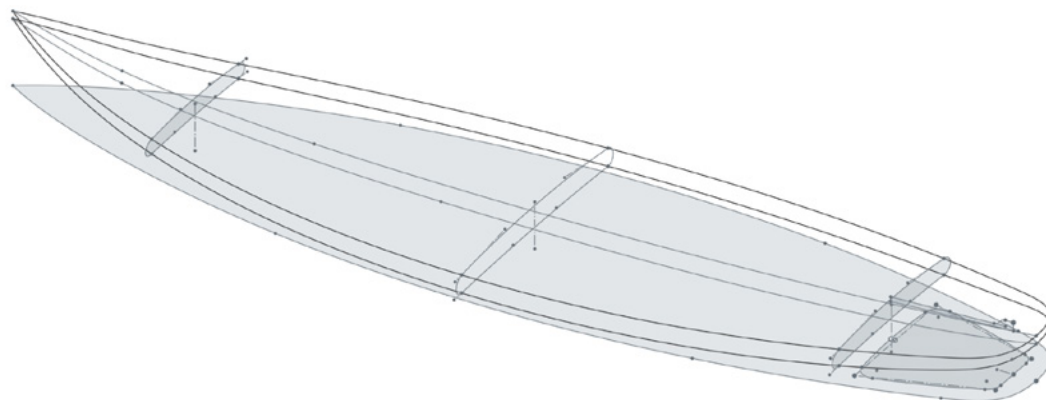

Image 1. Wireframe of Surfboard Design

Benefit: Wireframes allow you to define the design intent of your project and build the geometric boundaries of the product.

Wireframes identify the flow and structure of products and are a useful tool in developing functional prototypes for final products. Wireframes in CAD, created parametrically, will enable you to refer to your original design intent and make changes once the product is complete.

The first thing to think about when surface modeling is to consider what the profile of the object looks like. In the surfboard model above, we want to consider its profile: from the top and the side view. These constraints will help define the Wireframe in forming the geometric boundaries of the object.

Something like a surfboard can be easy to define because the profile is not overly complicated; this type of product is a good starting point for anyone looking to get into surfacing.

When you want to design something a little more complex, start by observing products that put a higher emphasis on aesthetics, such as an Earpod. Wireframes contain the design intent, defining the building blocks of your product. In Image #2, the Earpods design is substantially more intricate in terms of surfacing as it involves a higher level of detail along more planes. Based on the Wireframe, you will need to define multiple pieces of construction geometry to help you build the structure for your product.

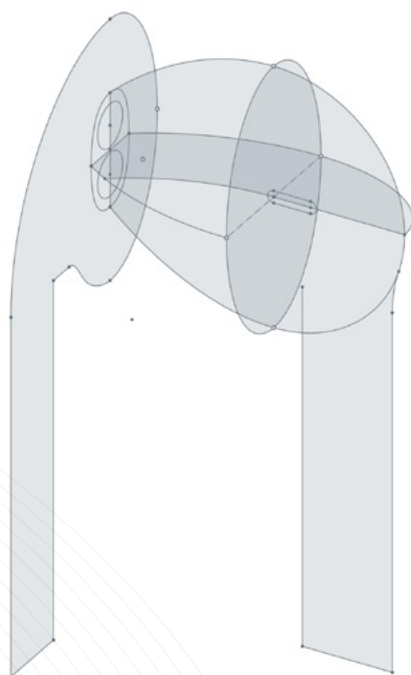

Image 2. Wireframe of Earpod design

2 Use Rendering to visualize your product before it's manufactured

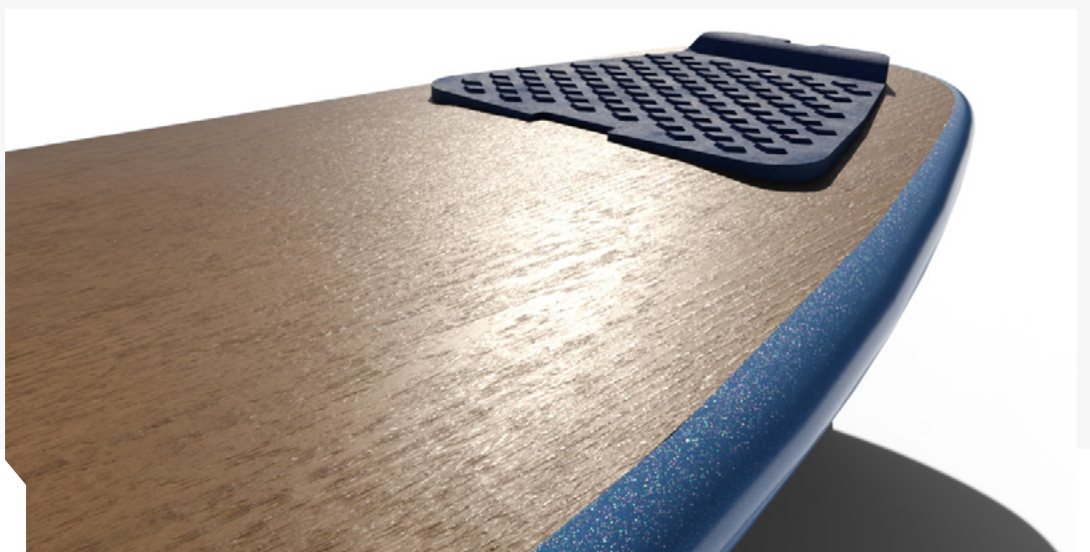

Image 3.
Rendered Surf Board

Benefit: Rendering gives you a realistic view of your design once manufactured, empowering you to review prototypes and ideation before moving to production.

Once we develop a clean surface model, we can take our industrial design process to the next level using rendering. Rendering refers to the process of incorporating lighting, color and texture to a 2-D or 3-D object in order to generate photorealistic imagery for use in product marketing and ideation.

Rendering with different materials or settings can be a great way to adjust your ideas and solicit feedback from key stakeholders. By using different materials and settings, you can create visuals that accurately represent your product. This tool can be especially useful when working with sales teams, customers, and marketing teams, as it allows them to have a better understanding of the product before it is fully completed.

It's incredible what can be accomplished in a purely digital setting with the use of rendering technologies and proficient surfacing abilities.



Image 4. Rendered Earpod

**MAKE YOUR PRODUCTS COME TO LIVE
AND CREATE PHOTOREALISTIC IMAGES
WITH RENDER STUDIO**

LEARN MORE

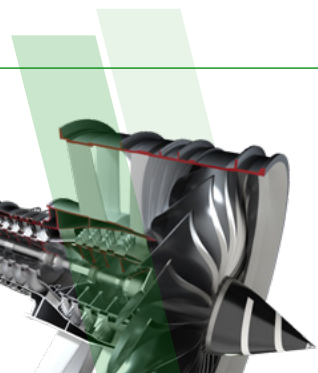

3 Use reference images when defining your Wireframe

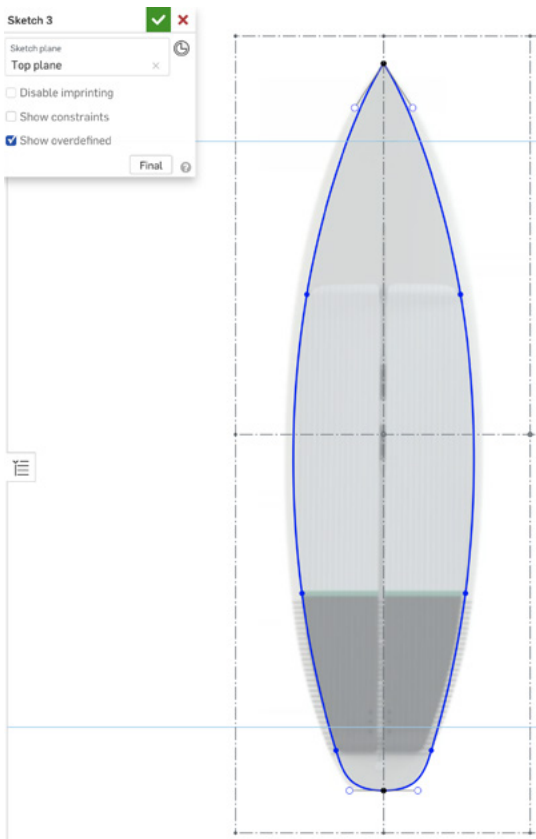

Image 5. Top View of Reference Sketch

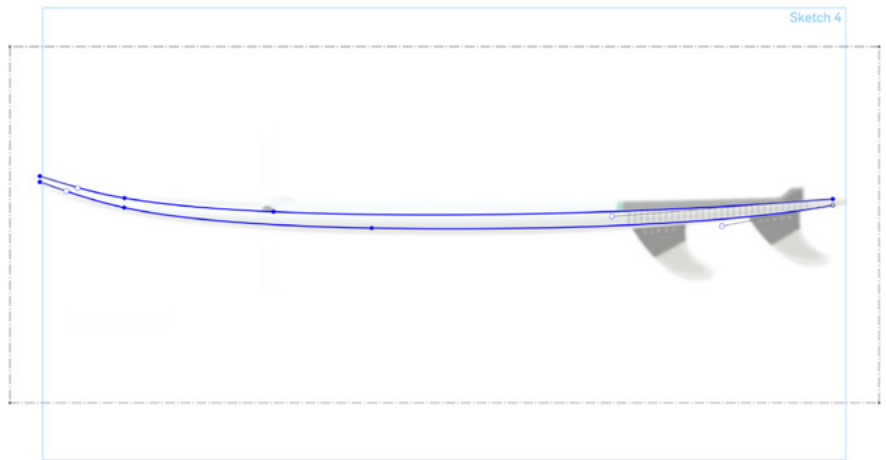

Image 6. Side View of Reference Sketch

Benefit: Quickly bring two-dimensional ideas into a 3D space by using reference images.

In images #5 and #6, we are referencing an existing product (i.e. the surfboard). If we were to redesign the surfboard from scratch, we could use these images of the existing product to quickly trace over the geometry and get started with our 3D representation.

In most industrial designs, we begin ideation with a pen and paper or by using 2D modeling tools. The most common and effective way to begin any surface model is to use some reference images. By overlaying three perspectives of the product in the Front, Right and Top planes, you can start using splines to trace the shape of the object. Using this technique, can allow you to quickly convert your pen and paper sketches into a fully realized parametric CAD model in a fraction of the time. Making changes to the object in the future should be fairly painless once you flesh out the model - this all starts with your basic sketches!



PRO TIP

By using reference images, you can draw inspiration from different sources and create something that stands out from the competition. Reference images can provide valuable insight into the design process, giving you the opportunity to learn from the successes and failures of other products.

4 Using Splines and Bezier Curves

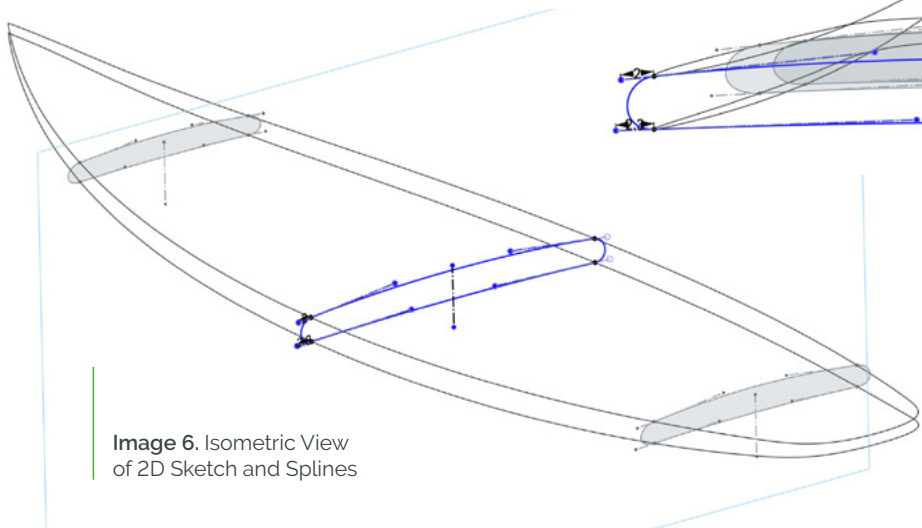

Image 6. Isometric View of 2D Sketch and Splines

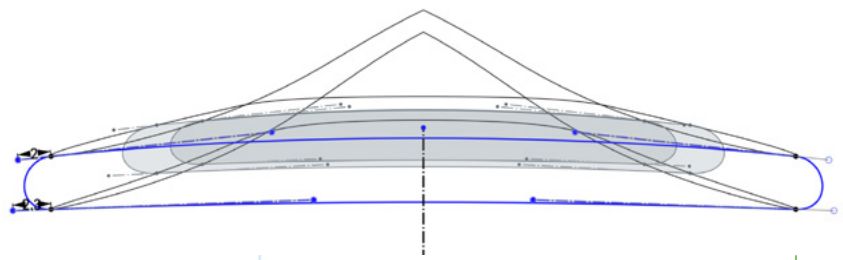
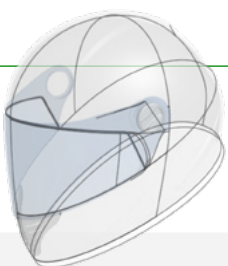

Image 7. Rear View of 2D Sketch and Splines

Benefit: Splines and Bezier Curves are flexible ways of modeling in 2D granting you the ability to define your Wireframe and constrain the continuity between curves and surfaces.

When you begin any surface design in 2D, you will be using a lot of Splines and Bezier Curves. These are powerful tools used to guide your surfaces as you create Lofts, Fills, Sweeps, and other features. Splines and Bezier Curves can be used to drive tangency and curvature across a sketch.

In more complex designs, you will begin to integrate 2D and 3D curves into your workflow to help delineate boundaries for the shapes you are working with.



SET YOURSELF UP TO SURFACE MORE COMPLEX PRODUCTS BY TAKING A LOOK AT OUR COURSE ON CURVES.

[LEARN MORE](#)



PRO TIP

By using reference images, you can draw inspiration from different sources and create something that stands out from the competition. Reference images can provide valuable insight into the design process, giving you the opportunity to learn from the successes and failures of other products.

5 Know the basics of creating a Loft

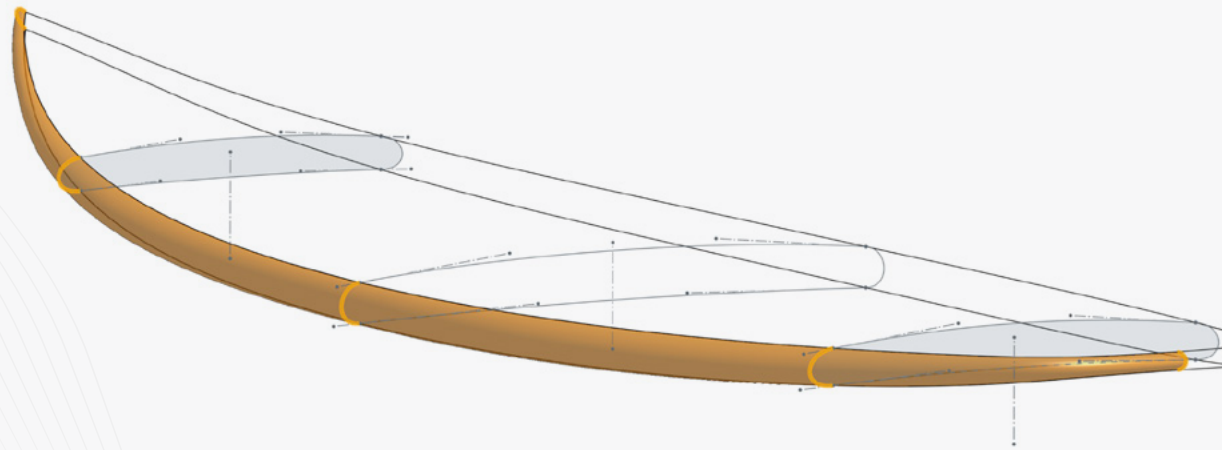

Image 8. Loft Across the Left Side of the Surfboard

Benefit: The Loft tool allows you to create geometry between multiple curves and shapes, as well as guide the geometry as you formulate it.

The Loft is arguably the most powerful tool in your surfacing arsenal. You can think of a loft as the stretching of a fabric over the wireframe. The more you learn about industrial design, the more you will notice all the geometry around you that requires a Loft to be defined, such as a guitar or car chassis.

In Image #9's Earpod Loft, we are increasing the level of control you exert over the design, using composite curves and control points. Using ISO lines you can better understand how the surface is being formed.

ISO lines are a set of standardized lines used to represent geographic features on a map. They are based on the International Organization for Standardization and are used by many organizations to show spatial data in a concise and easy to read format. ISO lines are used to indicate boundaries, roads, rivers, and contour lines, among other things, making them a great tool for anyone looking to analyze and visualize spatial data.

ISO lines are used in surface modeling to represent contours of constant values, such as elevation or slope. ISO lines are used to help visualize and analyze a particular area, allowing for the measurement of surface features such as height, slope, and curvature.

Composite curves offer a technique that combines multiple curves to create a single curve reference, often resulting in better surfaces. These curves can be either open or closed, and may be composed of straight lines, arcs, circles, or more complex curves. Composite curves are often used in the design of complex or organic shapes which would otherwise be difficult or impossible to model. The advantage of composite curves is that they can be easily adjusted or modified to achieve the desired shape without having to redraw the entire surface.

Image 9. Isometric view of Earpod Loft

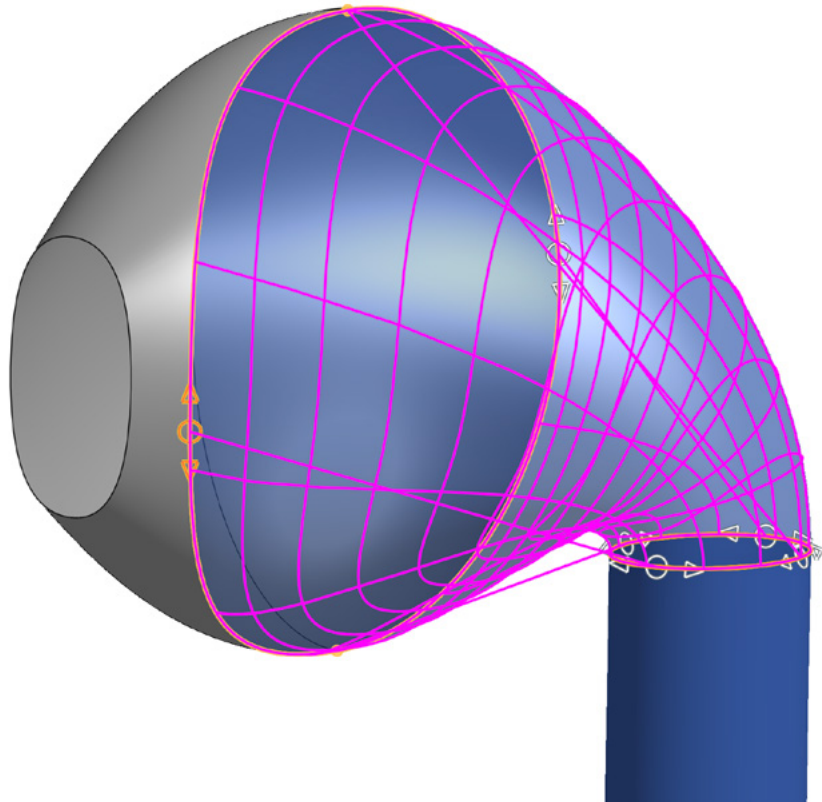

PRO TIP

When you create Lofts, the use of guides, points and clean transitions will become increasingly important. The time and effort required to rectify improperly constructed geometry can be costly.

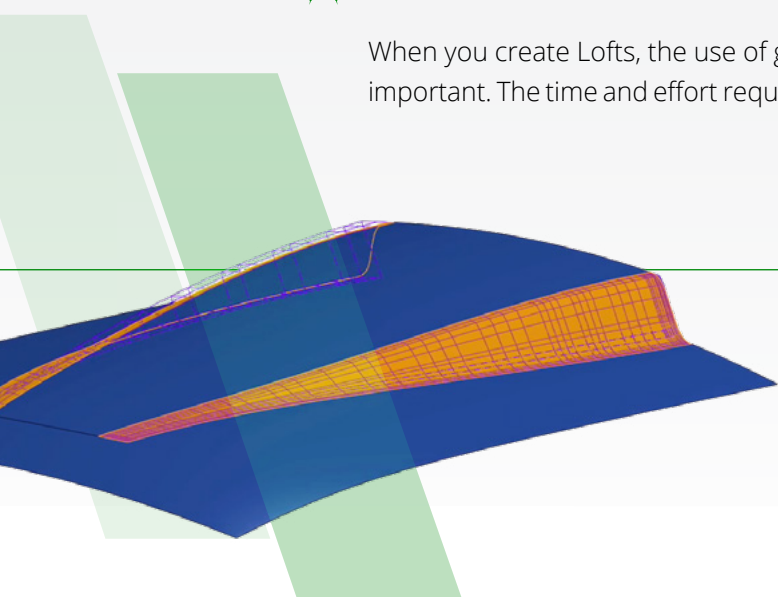

DIFFERENT SITUATIONS CALL FOR DIFFERENT APPROACHES TO MODELING, LEARN THE CORE DIFFERENCES BETWEEN FILL, LOFT AND BOUNDARY SURFACES IN THIS TECH TIP

LEARN MORE

6 Create 3D Curves to use as guides

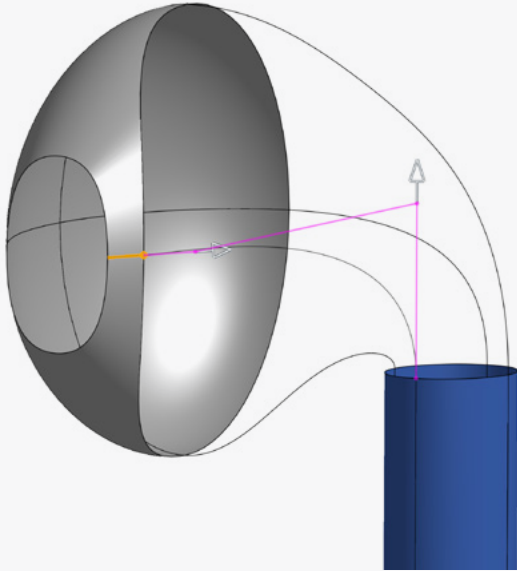

Image 10. Using 3D Curves to Guide a Loft

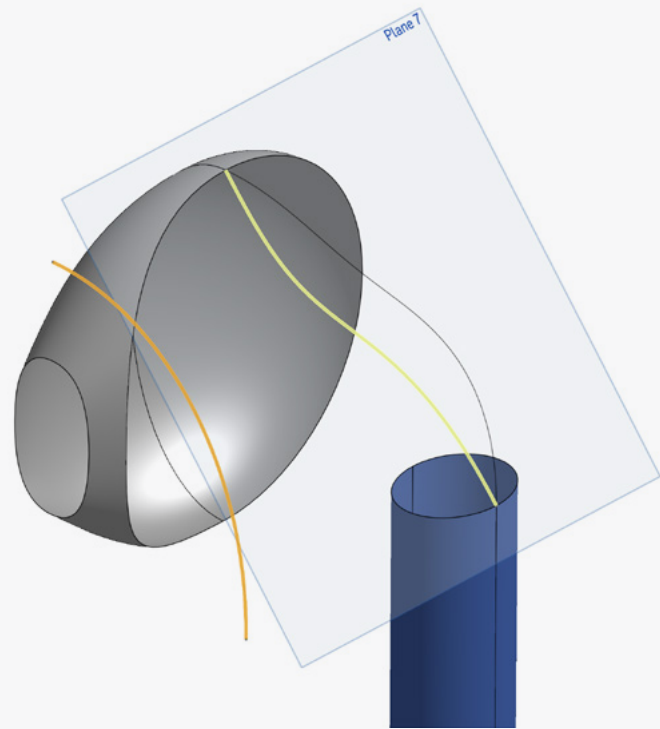

Image 11. Projecting Two 2D Curves onto Each Other to Generate a 3D Curve

Benefit: 3D Curves are the fastest way to create guiding geometry for you surfaces

Using 3D curve features is the quickest way to define guiding geometry without having to create multiple planes and sketches. Sometimes the only way to achieve something is through a 3D curve. Two of the most popular 3D curves are the Bridging Curve and the Projected Curve.

The Bridging Curve is a quick and effective feature for creating guidelines. Bridging Curves are generated by choosing a connected curve and point combination, which will define a start direction and an end point for the curve. We can further constrain the bridging curve through tangency and curvature. In image #10, you can see the guide we can generate for the Loft combining the Bridging Curve and Projected Curve.

The Projected Curve lets you take two curves in two sketches and project them onto each other. In image #11, you can see the two highlighted curves we projected onto each other to generate a three dimensional curve — this is a powerful way of building geometry. Both splines are built in different planes when using the Projected Curve feature. Through the use of 3D curves, the task of constructing the required Wireframes becomes feasible.

7 Understand Curvature Continuity

Image 12. 3 Levels of Geometric Continuity. Image provided by [wikipedia](#)

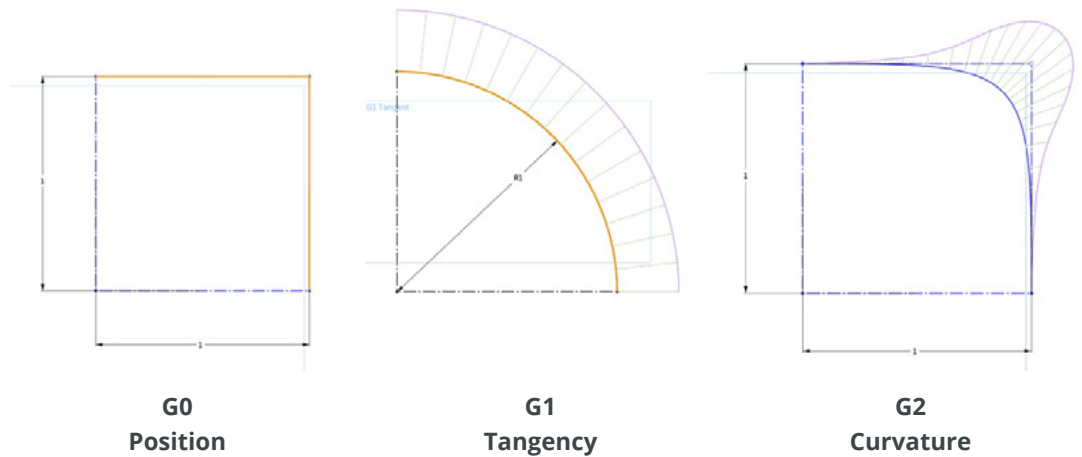

Benefit: Without a clear understanding of Curvature Continuity the exterior of your final products will not look aesthetically pleasing.

As we dive deeper into the world of surfaces, we need to start gaining an appreciation for the different types of curvature continuity. You can consider the transition from any one curve to the next in the terms of G0 or position, G1 or tangency, G2 or curvature, refer to image #12 for visual understanding. It is most common for designers to use G1 or G2 curvature in communications with other industrial designers.

As we start blending surfaces into each other, curve continuity starts gaining more importance.

Clean curvature helps reduce stress on components and materials, which can help extend the product's lifespan. Furthermore, curve continuity can be used to create a sense of harmony and unity, which gives a product a more professional and sophisticated look. In short, curve continuity is an important part of industrial design because it helps make products more attractive, efficient, and durable.

8 Conduct a Surface Analysis using Zebra, Curvature and Surface Continuity

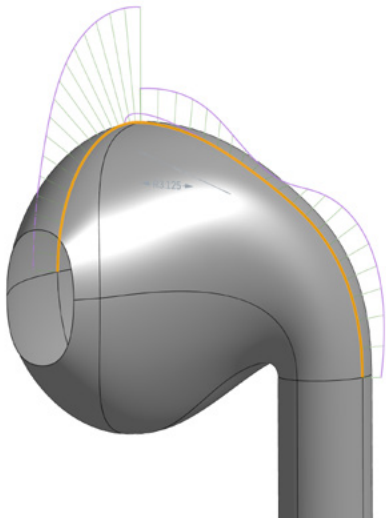

Image 13. Analyzing Continuity of a Curve



Image 14. Zebra Stripes Analysis

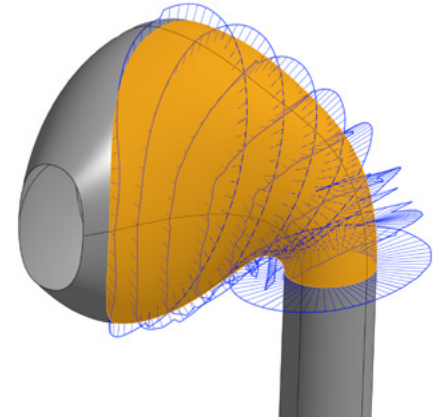

Image 15. Surface Curvature

Benefit: To optimize our surfaces and provide the best possible design we first need to understand them

Here are three of the most widely utilized methods of analysis. Curvature continuity, Zebra Stripes and Surface continuity.

Curvature continuity is the idea that a curve should be continuous and smooth, without abrupt changes in direction to its shape. This is important because it allows for natural-looking shapes and surfaces, making it easier to comprehend and visualize. This form of analysis makes it easier to calculate things like derivatives, integrals, and other mathematical functions along the curve.

Zebra stripes are used to analyze the curvature continuity between surfaces. To achieve the best surface finish, you want flowing curves that transition cleanly from one to the next. You can identify G0 continuity through hard directional transitions, without connecting stripes. G1 will have connected stripes, but the stripes will veer away from one another. G2 will have connected stripes and they will not have any aggressive changes in direction.

Surface Curvature is the measure of how curved a surface is. It is the amount by which the surface deviates from a flat plane. It is typically measured in terms of the radius of a circle that best fits the surface. Surface Curvature helps you identify issues through hard spikes and sharp straight lines, indicating folds, or surface defects.

9 Iterate quickly with the “Branching and Merging” functionality

Image 16. Versions and History Graph

Name	Modified
Main	Nacho Owner 14:18 Today
> Show changes...	
Updated Performance	Nacho Owner 9:40 Feb 23
> Show changes...	
Pre Render Changes	Nacho Owner 11:54 Feb 8
> Show changes...	
V17	Nacho Owner 12:57 Jul 27 2021
> Show changes...	
V16	Nacho Owner 12:56 Jul 27 2021
> Show changes...	
2 Fins	System 7:57 Apr 20 2021
> Show changes...	
Finished Data Set	Nacho Owner 18:47 Oct 8 2020
> Show changes...	
Show Room Done	Nacho Owner 18:05 Sep 24 2020
> Show changes...	
Performance Board Com...	Nacho Owner 17:10 Sep 23 2020
> Show changes...	
Fish Main Body Done	Nacho Owner 13:27 Sep 16 2020
> Show changes...	
ShowRoom V1 Completed	Nacho Owner 16:38 Sep 15 2020
> Show changes...	
First CFD Set Up	Nacho Owner 12:23 Sep 4 2020
> Show changes...	
First Board Fully Assemb...	Nacho Owner 17:58 Sep 3 2020
> Show changes...	
Working Parts	Nacho Owner 17:56 Sep 3 2020
> Show changes...	
Working Model	Nacho Owner 13:48 Sep 3 2020
> Show changes...	
New Iteration	Nacho Owner 15:50 Sep 2 2020
> Show changes...	
V5	Nacho Owner 13:54 Sep 2 2020
> Show changes...	
Assembly Done	Nacho Owner 12:18 Sep 2 2020
> Show changes...	
1 Fin	Nacho Owner 12:16 Sep 2 2020
> Show changes...	

Benefit: Visual data management helps designers create iterations of their product faster with more accurate data handling and better outcomes in the Product Lifecycle.

PDM functionality which supports the exploration of a design space can be a massive benefit to how you approach design, allowing you to iterate more quickly on your design ideas. Onshape’s PDM supports git like Branching and Merging to help you speed up your product development process by providing you with an agile approach to design exploration.

10 Parametrically drive Surface Design

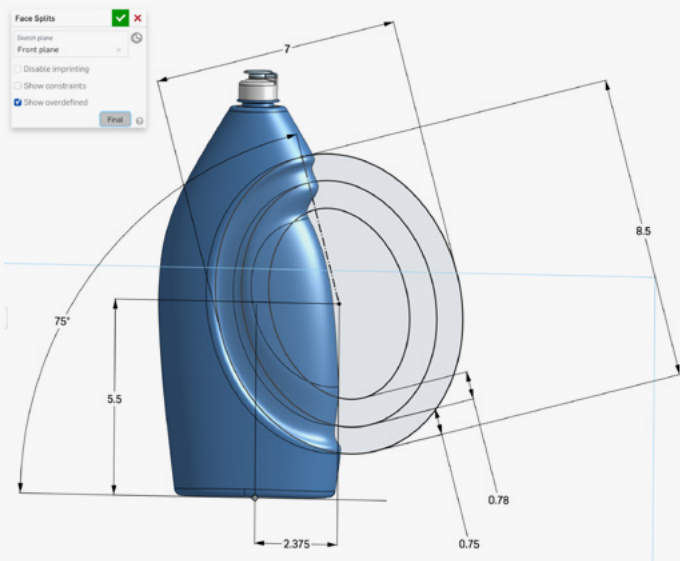

Image 17. Visualized design using Final Button

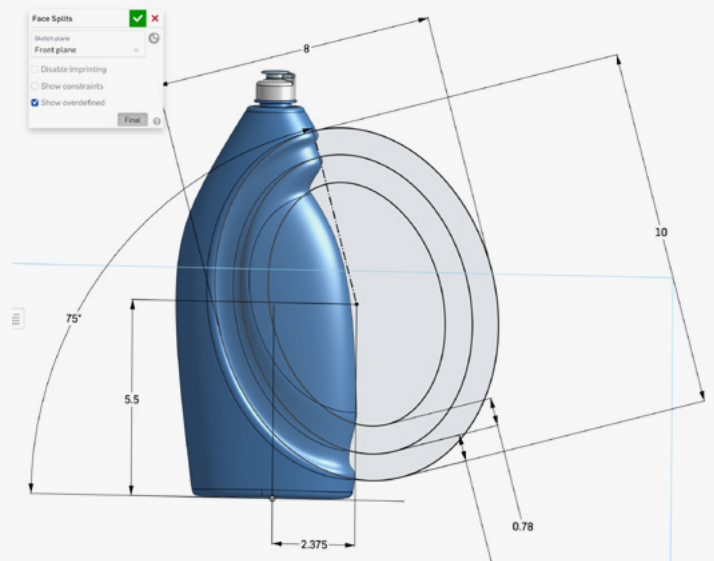

Image 18. Proposed New Design Using Final Button

Benefit: Parametric models are more robust, have higher reusability and allow product designers to produce a wide array of options quickly, always maintaining design intent

With parametrically driven design work, you can create flexible models that allow you to quickly change the final output by leveraging a driving sketch. Using a Final Button you can see how your design will regenerate without actually committing a feature. When your designs have strong parametrization it will become much easier to iterate and change the outcome of the geometry. This allows you to be able to output many design options from a single master reference, empowering decision making and final product decisions.

Design Better With Cloud-native CAD

The only Cloud-native CAD solution available today that enables all of these surfacing methodologies into a single, easy-to-use platform is Onshape.

Onshape's Master Modeling and Cloud based technologies make it easier than ever to quickly design complex surfaces with more accurate results.

Using these technologies, engineers can model parametrically, reuse geometry and components, and create models that are updated in real-time. This ensures that product designs are better, faster, and cheaper than ever before!

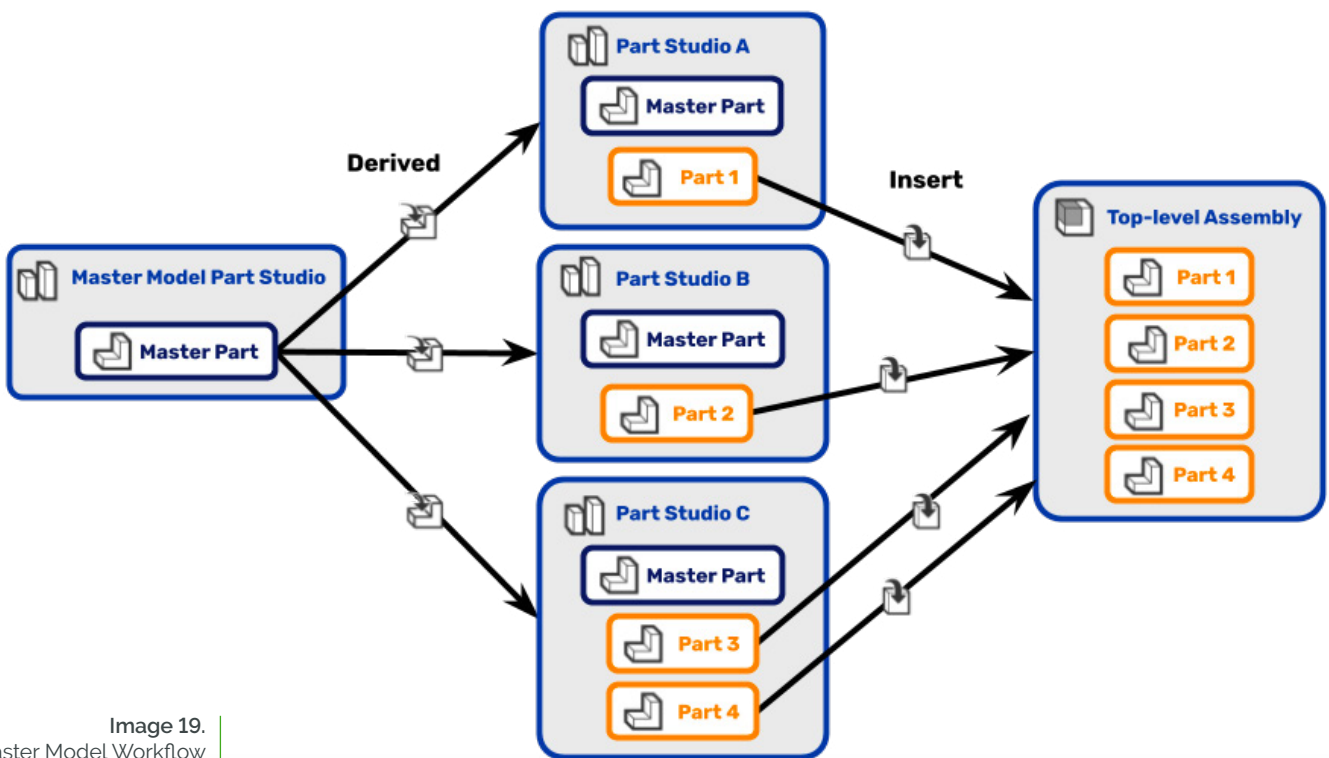

Image 19. Master Model Workflow



Surfacing methodologies can be daunting, as they take a lot of forethought and design intent.

By having a clear idea of the products you wish to develop and focusing on the core driving components of your surfaces, you will achieve the best and most iterable designs.

We hope these tips help you better understand surfacing workflows.

To learn more about how Onshape can transform your product development processes, try Onshape Professional Today!

GET STARTED

